

# Neoliberalism: Cultural Aspects

One of a series of interconnected notes prepared by Acción Zapatista de Austin ([www.utexas.edu/students/nave](http://www.utexas.edu/students/nave))

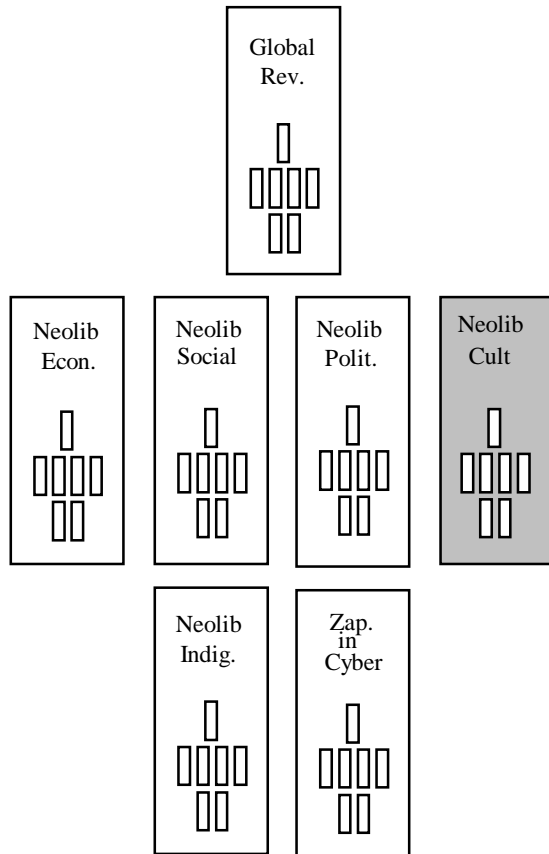

## Neoliberalism and Culture

As the current phase of capitalism, neoliberalism necessarily involves the manipulation of culture for purposes of domination and subordination. Understood as a dynamic and plural process, "culture" refers to all of those ways in which we make sense of the world: images, stories, desires, identities, intellectual work, spiritual development and aesthetic undertakings. Emerging historically in response to a cycle of struggle that included very powerful cultural components, neoliberalism has sought to commodify, instrumentalize or destroy all those cultural activities that have undermined capitalism while pushing the human experience in new directions.

Thus, in response to the struggles of cultural and ethnic "minorities" for a true cultural pluralism where their differences are accepted and valued, neoliberalism has responded with educational and corporate multiculturalism within which these differences are given token recognition within a context of accentuated hierarchy. In the US Chicanos are allowed to honor labor leader Cesar Chavez while, at the same time, racism is intensified against *Mexicanos* along the border. Cable TV allows local communities some autonomous cultural expression, while an increasingly concentrated corporate culture industry pumps a flood of Western images, narratives and worldviews into the rest of the world -- accentuating the marginalization of that autonomy. Such cultural strategies amount to a new stage of what we might call the flexible homogenization of world culture.

## Resisting Neoliberal Culture

Such cultural strategies, however, have not succeeded in reducing everyone to passive subjects or co-optable active ones. People continue to maintain and invent alternative cultural traditions of resistance and "do not plan to die though they may be killed." New intersections between people in the North and South produce ungovernable alliances. Autonomous desires continue to produce values and social relations to which business has always been hostile, including sisterhood and brotherhood and the formation of communities where individuals can define themselves beyond consumerism within collective, shared, and idiosyncratic frames.

Against the business reduction of cultural difference to trivial variations among similar commodities, the valuing and respecting of differences among groups has become an essential political priority. The multiple Zapatista

initiatives to call upon ALL sectors of civil society is culturally as well as politically instructive. This directs us to the experiences of everyday life, which is precisely where a revolution to make possible a revolution must occur, which is to say, ... a revolution in culture. The homogenizing and universalizing forces of business and its Left mirror must give way to endless dialogue and the elaboration of new non-hierarchical relations across cultural difference. This too is Zapatismo!

## Cultural Struggle

Axes of differentiation such as gender, sexuality, and ethnicity are constitutive of cultures, even when they regard themselves as unified and insular. Cultural projects of discovering, telling, and revaluing denigrated identities and histories is absolutely essential to the political project of creating the space within which a dialogue can take place between equal political subjects. Thus our struggle against global, neoliberal capital must confront sexism, racism, homophobia, casteism, and religious/ethnic violence, all of which intersect to form the existing structures of domination. At the same time, we must also undertake the very difficult work of translation across sectors and positions, a project that seeks interconnectedness within the context of autonomy.

Essential to the further elaboration of cultural struggles is the democratization of the means through which people can become cultural producers and have access to a range of audiences. New media technologies, like the Internet (and related computer projects like ZAPNET! on CD-ROM), micro radio, public access cable and satellite stations, and cheap video equipment for popular filmmaking, all offer the potential for extending the means of cross-cultural expression to hitherto excluded voices. To create more space for such activities we can also fight for a roll-back of the current concentrated corporate domination of the means of cultural expression.

In cultures based on the domination of many by the few differences are manipulated to divide and conquer. This necessarily involves the creation or reinforcement of hostility and intolerance toward those outside particular traditions. In a truly pluricultural world, differences can be valued as essential stimuli to mutual development. Such a new political culture has been under construction for some time. Its development is an essential component of rebuilding the world exemplary model of this movement. This forum allows for permanent dialog among indigenous communities and opportunities for joint action against potentially devastating neoliberal policies at both local and national levels.

"It is necessary to construct a new political culture.... There are no recipes, lines, strategies, tactics, laws, regulations or universal slogans. There is only one desire: to construct a better world, that is, a new one."  
Subcomandante Marcos, May 1996