

# A METHOD FOR SORTING BOTTOM FAUNA SAMPLES BY ELUTRIATION<sup>1</sup>

*George H. Lauff and Kenneth W. Cummins*

Department of Zoology, University of Michigan, Ann Arbor

*Clyde H. Eriksen*

Department of Zoology, Los Angeles State College

*Michael Parker*

Department of Zoology, University of Wisconsin, Madison

## ABSTRACT

A sorting device based on mechanical agitation of a substrate sample in a water column, followed by elutriation, provides a rapid and convenient method of separating benthic faunal components and finer sediment fractions. The operation is efficient in terms of total time of analysis and the percentage of animals removed. The method is versatile and can be modified to meet the needs of specific sampling programs.

## INTRODUCTION

During the course of a study on the role of substrate in fauna distribution on stream bottoms, a sorting tube was developed for separating macro-invertebrates from substrate samples. The same device was employed to remove silt and clay fractions from substrate samples in preparation for mechanical analysis (Cummins 1961). The sorting apparatus, or "bubbler," relies on mechanical agitation of a substrate sample by a battery of small air and water jets which place all but the heaviest materials in suspension in a water column. Separation is achieved through differential settling rates resulting from variations in the specific gravity and general shape of suspended materials. Further separation can be obtained by employing a series of small graded sieves below the outflow when the desired suspended fraction is tapped off.

The removal of macro-invertebrates from benthic samples is extremely time consuming and accuracy often varies according to the particular procedure employed. Jonasson (1958) has discussed aspects of sieving with particular regard to mesh size, while Anderson (1959) has reviewed the various flotation techniques for the sorting of macro-invertebrates from sieved substrate samples and described his own method em-

ploying a sugar solution. Moon (1935) and Allen (1951) used variations of an elutriation technique for sorting stream samples but their devices were quite cumbersome.

The bubbler described below has proven to be very effective in separating the benthic invertebrate fauna from a variety of lake and stream sediments. It offers considerable savings in time over the more conventional sieving and hand-picking or flotation methods, as well as separating the organisms into general size categories. The device is quite versatile since a whole substrate sample can be treated in the case of a small sampler, or large samples can be proportioned or can receive a preliminary sieving in the field to reduce their volume prior to sorting.

## CONSTRUCTION

Figure 1 illustrates the construction of the bubbler; none of the dimensions are critical except the length of the main tube which must be sufficiently long to permit rapid agitation of the sample without overflow. The main tube of the bubbler and the drain spout are made from acrylic plastic tubes. The plunger brace (guide) and the three base pieces are cut from  $\frac{3}{8}$ -in. plexiglass. The plunger brace is glued inside the drain spout with a general purpose acrylic cement; wire brads provide a necessary anchor for this piece. The drain spout and upper base piece (insert 1) are

<sup>1</sup>This apparatus was designed and constructed in connection with a project supported by the National Institutes of Health.

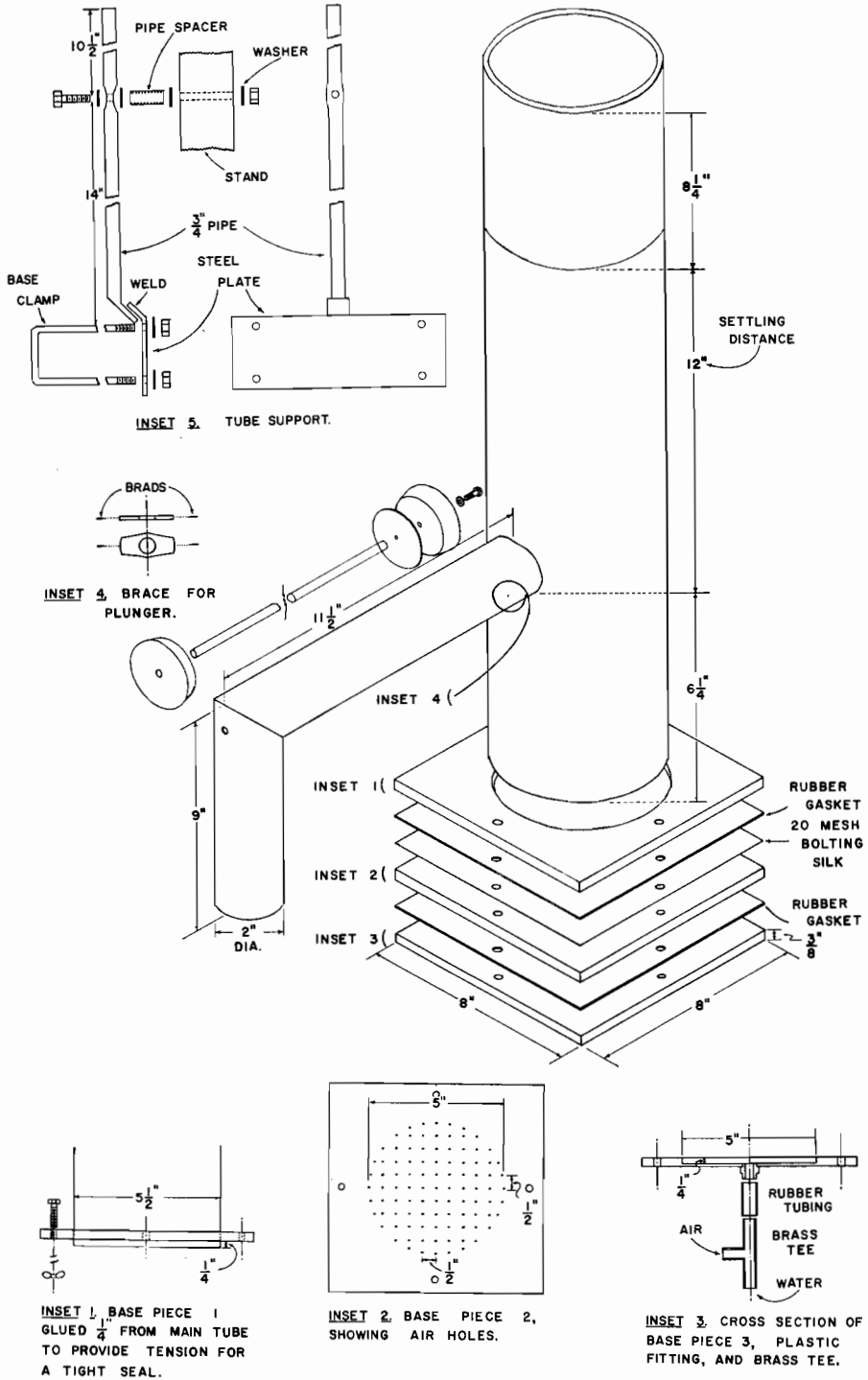

FIG. 1. An apparatus for sorting bottom fauna samples by elutriation.

securely glued to the main tube. The latter is attached approximately  $\frac{1}{4}$  in. from the end of the tube to permit adequate tension to be developed, thus providing a tight seal between the base components. The central piece (insert 2) is perforated by a number of minute holes ( $\frac{1}{16}$  in. diameter), while the lower base piece (insert 3) has a recess  $\frac{1}{4}$  in. deep and 5 in. in diameter to provide a uniform distribution of both air and water. A short, rigid plastic tube facilitates the attachment of the combined air-water inlet. The seal between the base pieces is maintained by rubber gaskets cut to fit. A piece of #20 silk bolting cloth is inserted above the central base piece to prevent clogging of the small holes. Wing nuts used to hold the base together facilitate quick take-down for replacement of the bolting silk.

The plunger consists of rubber stoppers secured to each end of a brass rod. The stopper which closes the outlet inside the main tube is bolted against a brass plate and into the rod. A spring (not shown) between the other stopper and the angle of the drain spout maintains tension on the plunger and prevents leaking.

The bubbler support is a  $\frac{3}{4}$ -in. pipe bent and welded to a steel plate, the latter having four holes for two U-bolts which clamp the base pieces to the support. Near the middle and top of the bubbler, rubber tubing is fastened around the main tube and support pipe for additional anchorage. This combination is then attached to the main stand (a stable vertical pipe) by a bolt through the support pipe and stand, with a spacer in between, which allows the apparatus to be pivoted or inverted for cleaning. The stand should be mobile, or installed adjacent to a laboratory sink; it could be modified to be mounted on a sink drain-board.

Both the water and air inlets should be controlled by appropriate faucets or stop-cocks.

#### PROCEDURE

Though there are several possible procedures for using the bubbler, the following was demonstrated to give best results

and was employed in obtaining the data presented below. After adding several inches of water to the tube to cushion the fall of heavy substrate materials, the sample was introduced by washing it from the sample container. Additional water was introduced, filling the tube to a line approximately 12 in. above the bottom of the drain spout. It is desirable to remove large cobbles or excessive amounts of vegetation from a sample by washing it through a coarse sieve (20–40 mm mesh) fitted over the top of the tube. Various sizes of sieves can be employed to catch the material tapped from the drain spout. The selection of sieve size is dictated by the size range of animals encountered, the smallest size category to be retained, and the nature of the substrate. The sieves must be inspected carefully since small organisms, especially midges and oligochaetes, tend to catch in drops of water underneath or pass undetected if too large a mesh is employed. We used a sieve with 2-mm mesh above one of 1 mm or 0.5 mm. Compressed air was introduced to agitate the sample sufficiently without loss of material from the top of the tube. From this point we used one of two methods; either the material in suspension was tapped off while the samples were being agitated, or the air was turned off two seconds before pushing the plunger. While the first method suspends most of the heavy animals (such as smaller mollusks and mineral case-bearing caddisflies), the second reduces the substrate caught on the sieves. Depending upon the amount of material retained by the sieves, organisms were picked directly from the sieves or washed into a white tray. Unless there were unusually large amounts of organic detritus, the residue on the screens was examined in a tray only after the fourth and final washing.

When the procedure (filling the tube, agitating the sample, tapping off the suspension, and removing the animals) had been repeated four times, the tube was inverted and the remaining material washed out by opening the water inlet. Four washings appeared to yield an optimum balance between effort and relative sorting effi-

TABLE 1. *Animals recovered in four washings from lake and stream samples*

Samples (location and no.)	Total number recovered	
	Bubbler	Residue
Lake (21)	219	17
Stream (36)	2,420	47

ciency. Occasionally an animal became attached to the bolting silk at the bottom of the tube making it advisable to inspect the tube before the introduction of the next sample.

The effectiveness of the bubbler in sorting benthic organisms was substantiated by determining the animals in the residue after four washings, and by the efficiency of recovery of a known number of naturally occurring benthic invertebrates which were added to specific samples. Twenty-one bottom samples were obtained with a 6-in. Ekman dredge in water depths ranging from 1.5 to 8 m. The substrate was a marly mixture of silt and sand with some vegetation, mostly *Chara*; the percentage of sand decreased with depth. Following conventional practice, the samples were sieved in the field using a screen having a 0.5-mm mesh. Substrate and the organisms retained were preserved and later used in evaluating the performance of the bubbler. Thirty-six bottom samples were taken from a small shallow stream where the substrate was composed largely of gravel, but contained slight amounts of silt, some sand, and pebbles. The samples were obtained using a cylinder sampling device (Cummins 1961), and the total sample was preserved in each case. Both the lake and stream faunas consisted primarily of tenipeditid larvae and *Tubifex* worms with

some leeches, nematodes, mollusks, amphipods, and various insect groups (Odonata, Ephemeroptera, Megaloptera, Trichoptera, Coleoptera, and other Diptera).

Selected bottom samples from both the lake and stream were treated to remove all animals present. A known number of naturally occurring benthic invertebrates were then added, and the samples were introduced into the bubbler. The known animals were obtained from lake and stream sediment samples which were agitated in the bubbler and washed into a 0.25-mm mesh sieve. A 0.5-mm mesh sieve was selected for the recovery experiments so that the animals retained would be within the size range normally selected by field sieving and hand-picking techniques.

#### RESULTS AND DISCUSSION

Table 1 gives the number of animals recovered in four washings in the 21 lake and 36 stream samples. The majority of the animals were recovered by the third washing, with the final washing adding only 2% and 4%, respectively. If the number of animals still remaining in the residue is used to determine the effectiveness in removal of the organisms, an average of 92% was recovered from the lake samples while 98% recovery was obtained from the stream samples. Two lake samples contained 12 of the total of 17 animals recovered from the residue, or approximately 70%. The specific reason for the discrepancy is not known, but it is suspected that the routine analysis procedure may have been altered inadvertently. The animals that remained in the residue were primarily midge larvae and *Tubifex* worms. However, their numbers in the residue were approximately proportional to their abun-

TABLE 2. *Recovery in four washings of known numbers of animals introduced into substrate samples*

Samples (location and no.)	Treatment	No. Introduced	Recovery		Residue		Unrecovered	
			No.	%	No.	%	No.	%
Lake (5)	Agitated	104	90	86.5	1	1.0	13	12.5
	Settled	98	90	91.8	5	5.1	3	3.1
Stream (4)	Agitated	355	317	89.3	3	0.8	35	9.9
	Settled	321	282	87.9	15	4.7	24	7.4

dance in the total sample. The bubbler was effective in sorting the smaller mollusks (*Sphaerium*, *Pisidium*, and *Ferrissia*) present; no mollusks were found in the lake sample residue, and only 3% of the total number of mollusks from the stream samples were present in the residue.

The introduction of a known number of benthic animals into substrate samples from which all animals had been previously removed provided an opportunity to determine the efficiency of the bubbler. Both the lake and stream samples indicated a recovery of approximately 89% (Table 2) using either the agitation or settling method. The agitation method was superior in recovering the heavier animals. It did not alter the recovery of the lighter animals, however.

A recovery of 89% of introduced animals is very good, particularly when one considers that a 0.25-mm sieve was employed in obtaining the animals initially. Since a 0.5-mm sieve was used in the comparative recovery trials, the data suggest that 8 to 9% of the animals were lost owing to their being too small to be retained by the larger sieve. The agitation method apparently contributes to the loss of the very small organisms because of the increased velocity of discharge at the drain spout. These animals could usually be recovered in the wash water indicating that the bubbler was actually effective in removing them. With this consideration, the efficiency of the apparatus with known samples can be considered to be approximately 97%.

The length of time required to analyze a sample varied from 15 to 45 min, depending upon the nature of the substrate. An average value for the 57 samples analyzed was approximately 25 min. These times compare favorably with the results obtained

by Anderson (1959) using the flotation technique, although close comparison is not possible because he gave no information on sample size or sediment type.

While percentage recoveries obtained with the bubbler equal or exceed those obtained by other techniques, the time required per sample and the convenience of operation also commend the method. The bubbler is especially valuable if used on samples which are to be analyzed in their entirety for substrate particle size. Such samples cannot be partially sieved in the field and hand-sorting is especially laborious. Also, flotation substances which interfere with sediment analysis cannot be employed. In addition, the device can be utilized to separate sediment fractions once empirical settling times have been derived.

The method can be modified to fit the particular needs of a given sampling program. For example, various settling times can be employed depending upon the abundance of different animal groups and the mesh sizes of the catch screens can be chosen so that animals of a desired size are retained.

#### REFERENCES

- ALLEN, K. R. 1951. The Horokiwi Stream. Bull. New Zealand Dept. Fish., **10**: 1-231.
- ANDERSON, R. O. 1959. A modified flotation technique for sorting bottom fauna samples. Limnol. Oceanogr., **4**: 223-225.
- CUMMINS, K. W. 1961. The micro-distribution of the caddisfly larvae *Pycnopsyche lepida* (Hagen) and *Pycnopsyche guttifer* (Walker) in a restricted portion of a small Michigan stream. Ph. D. Dissertation, University of Michigan. 158 pp.
- JONASSON, P. M. 1958. The mesh factor in sieving techniques. Verh. int. Ver. Limnol., **13**: 860-866.
- MOON, H. P. 1935. Methods and apparatus suitable for an investigation of the littoral region of oligotrophic lakes. Int. Rev. Hydrobiol., **32**: 319-333.