



User's Manual

Purifier[®] Delta[®] Series Biological Safety Cabinets

Models

36200 Series

36201 Series

36204 Series

36205 Series

36208 Series

36209 Series

36212 Series

36213 Series

To receive important product updates,
complete your product registration card
online at register.labconco.com



*Protecting your
laboratory environment*

LABCONCO[®]

Labconco Corporation
8811 Prospect Avenue
Kansas City, MO 64132-2696
800-821-5525, 816-333-8811
FAX 816-363-0130
E-MAIL labconco@labconco.com
HOME PAGE www.labconco.com

Please read the User's Manual before operating the equipment.

The information contained in this manual and the accompanying products are copyrighted and all rights reserved by Labconco Corporation. Labconco Corporation reserves the right to make periodic design changes without obligation to notify any person or entity of such change.

Warranty

Labconco provides a warranty on all parts and factory workmanship. The warranty includes areas of defective material and workmanship, provided such defect results from normal and proper use of the equipment.

The warranty for all Labconco products will expire one year from date of installation or two years from date of shipment from Labconco, whichever is sooner, except the following;

- Purifier® Delta® Series Biological Safety Cabinets and PuriCare® Lab Animal Research Stations carry a three-year warranty from date of installation or four years from date of shipment from Labconco, whichever is sooner.
- SteamScrubber® & FlaskScrubber® Glassware Washers carry a two-year warranty from date of installation or three years from date of shipment from Labconco, whichever is sooner.
- Blood Drawing Chairs carry a ten year warranty.
- Carts carry a lifetime warranty.
- Glassware is not warranted from breakage when dropped or mishandled.

This limited warranty covers parts and labor, but not transportation and insurance charges. In the event of a warranty claim, contact Labconco Corporation or the dealer who sold you the product. If the cause is determined to be a manufacturing fault, the dealer or Labconco Corporation will repair or replace all defective parts to restore the unit to operation. Under no circumstances shall Labconco Corporation be liable for indirect, consequential, or special damages of any kind. This statement may be altered by a specific published amendment. No individual has authorization to alter the provisions of this warranty policy or its amendments. Lamps and filters are not covered by this warranty. Damage due to corrosion or accidental breakage is not covered.

Returned or Damaged Goods

Do not return goods without the prior authorization from Labconco. Unauthorized returns will not be accepted. If your shipment was damaged in transit, you must file a claim directly with the freight carrier. Labconco Corporation and its dealers are not responsible for shipping damages.

The United States Interstate Commerce Commission rules require that claims be filed with the delivery carrier within fifteen (15) days of delivery.

Limitation of Liability

The disposal and/or emission of substances used in connection with this equipment may be governed by various federal, state, or local regulations. All users of this equipment are required to become familiar with any regulations that apply in the user's area concerning the dumping of waste materials in or upon water, land, or air and to comply with such regulations. Labconco Corporation is held harmless with respect to user's compliance with such regulations.

Contacting Labconco Corporation

If you have questions that are not addressed in this manual, or if you need technical assistance, contact Labconco's Customer Service Department or Labconco's Product Service Department at 1-800-821-5525 or 1-816-333-8811, between the hours of 7:00 a.m. and 6:00 p.m., Central Standard Time.

TABLE OF CONTENTS

CHAPTER 1: INTRODUCTION	1
CHAPTER 2: PREREQUISITES	2
Location Requirements	2
Space Requirements	3
Clearance	3
Exhaust Requirements	3
Electrical Requirements	4
Service Line Requirements	5
CHAPTER 3: GETTING STARTED	6
Unpacking Your Biosafety Cabinet	7
Purifier Components	7
Moving the Delta	9
Preparing the Purifier for Operation	9
Installing the Purifier on an Existing Work Surface	9
Installing the Purifier on the Labconco Base Stand	9
Telescoping Base Stands	10
Manual or Electric Hydraulic Lift Base Stands	11
Connecting the Purifier to Service Lines	12
Optional Exhaust System Connections	13
Drain Valve Installation	13
Initial Certification	15
CHAPTER 4: PERFORMANCE FEATURES AND SAFETY	
PRECAUTIONS	16
HEPA Filters	16
Laminar Airflow	17
Directional Airflow	19
Motor/Blower	20
Cabinet Air Intakes (Grilles), Ductwork & Air Balance Controls	20
Ultraviolet (UV) Lamp	21
Safety Precautions	21

CHAPTER 5: USING YOUR CABINET	24
Operating the Sliding Sash	24
If The Alarm Activates	27
Resetting the Alarm	27
Working in Your Purifier	27
Safety and Comfort	29
Arranging Your Work Area	32
CHAPTER 6: MAINTAINING YOUR CABINET	36
Routine Maintenance Schedule	36
Service Operations	37
Work Surface Removal	37
Towel Catch Removal	37
Front Panel Removal	39
Changing the Fluorescent Lamp	40
Changing the UV Lamp	40
Resetting a Circuit Breaker	41
Downflow Velocities	41
Downflow Velocity Grid Patterns	41
Inflow Velocity Calculation – Primary Method	42
Inflow Velocity Calculation – Secondary Method	42
Calibration of the Type A2 Inflow Alarm	44
Calibration of the Type B3 Face Velocity Alarm	46
Electronics Module Access	47
Measuring Line and Motor Voltage	48
Speed Control Adjustment	50
Exhaust Control System Adjustment	51
Canopy Airflow Adjustment	53
Measuring the Total Exhaust Volume	53
Use of the Access Tube for DOP Testing	54
HEPA Filter Replacement	54
Motor/Blower Maintenance & Replacement	58
Diffuser Removal	59
Storage	60
Decontamination	60
CHAPTER 7: MODIFYING YOUR CABINET	61
Installing a UV Lamp	61
Installing Additional Service Fixtures	63
Installing the IV Bar for the 3' and 4'	64
Installing the IV Bar for the 5' and 6'	65
Canopy Connection Kits	66
Exhaust System Requirements	67
Installing the Canopy Kit	68
On Delta Models with the Variable Orifice System	68
On Delta Models already equipped with Guillotine Damper	69

CHAPTER 8: TROUBLESHOOTING	70
APPENDIX A: COMPONENTS	72
APPENDIX B: DIMENSIONS	74
APPENDIX C: SPECIFICATIONS	75
Electrical Data	75
Motor Specifications	75
Environmental Conditions	76
APPENDIX D: ACCESSORIES	77
Safety Orange Air Foil	77
Telescoping Base Stands	77
Manual or Electric Hydraulic Lift Base Stands	77
Service Valve Kit	78
Ultraviolet Lamp Kits	78
IV Bar Kits	78
Damper -Canopy Kit	78
Canopy Kit	78
Remote Blower	79
Ergonomic Chair	79
Adjustable Footrest	79
APPENDIX E: QUICK CHART	80
DECLARATION OF CONFORMITY	82

Chapter 1: Introduction

Congratulations on your purchase of a Labconco Purifier Delta Series Biosafety Cabinet. Your Purifier is designed to protect you, your product and your laboratory environment from biohazardous aerosols. The Delta is the result of years of experience in manufacturing biohazard cabinetry, and users like you suggested many of its features to us.

The Purifier offers many unique features to enhance safety, performance and ergonomics. To take full advantage of them, please acquaint yourself with this manual and keep it handy for future reference. If you are unfamiliar with how biosafety cabinets operate, please review Chapter 4: Performance Features and Safety Precautions before you begin working in the cabinet. Even if you are an experienced biosafety cabinet user, please review Chapter 5: Using Your Cabinet; it describes your Purifier's features so that you can use the cabinet efficiently.

A copy of this manual and other technical information is available at our website: www.labconco.com.

Chapter 2: Prerequisites

Before you install your biosafety cabinet, you need to prepare your site for installation. Carefully examine the location where you intend to install your cabinet. You must be certain that the area is level and of solid construction. In addition, a dedicated source of electrical power must be located near the installation site.

Carefully read this chapter to learn:

- The location requirements for your installation site.
- The electrical power requirements for your installation site.
- The exhaust requirements for your installation site.
- The service line requirements for your installation site.
- The space requirements for your installation site.

Refer to Appendix C: Specifications for complete biosafety cabinet electrical and environmental conditions, specifications and requirements.

Location Requirements

Note: The Purifier should be located away from traffic patterns, doors, fans, ventilation registers, fume hoods and any other air-handling device that could disrupt its airflow patterns. All windows in the room should be closed.

Figure 2-1 shows the optimum location for the Purifier.

Space Requirements

The dimensions for the different models are shown in Appendix B: Dimensions.

Clearance

Deltas not connected to an exhaust system should have at least six inches (150 mm) clearance from any overhead obstructions when the cabinet is in its final operating position.

A clearance of at least 6 inches (150 mm) should be maintained on both sides of the cabinet, as well as 12 inches behind the unit.

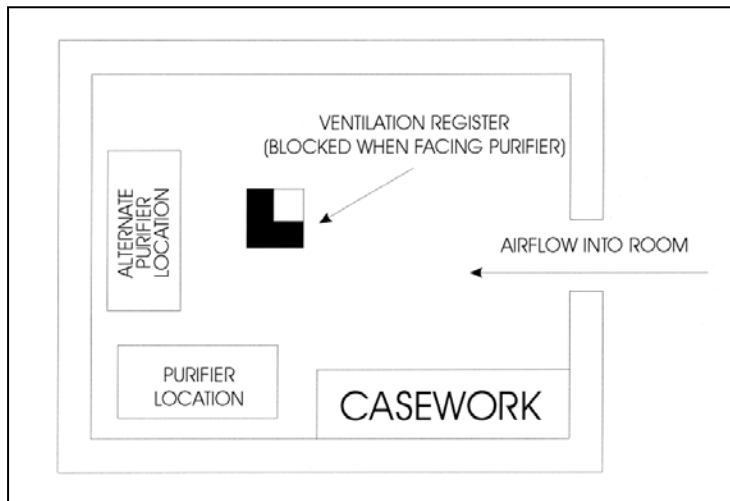

Figure 2-1

Exhaust Requirements

If you intend to connect your Purifier to the optional canopy connection kit, first examine the location to ensure that it is compatible with the cabinet's exhaust duct. The area directly above the cabinet's exhaust port should be clear of structural elements, water and utility lines, or other fixed obstructions. There should be enough clearance to allow for the passage of a 10" duct. Avoid cabinet locations that require either an elbow directly on top of the cabinet's exhaust connection or an excessive number of elbows to clear other items. For a further discussion of the cabinet's exhaust system requirements, please go to Chapter 3: Getting Started.

Electrical Requirements

The different Purifier models have the following electrical requirements:

Model #	Requirements
3620400-09	115 VAC, 60 Hz, 12 Amps
3620500-09	115 VAC, 60 Hz, 12 Amps
3620510-19	100 VAC, 50/60 Hz, 12 Amps
3620520-29	230 VAC, 50/60 Hz, 6 Amps
3620800-09	115 VAC, 60 Hz, 12 Amps
3620900-09	115 VAC, 60 Hz, 12 Amps
3620910-19	100 VAC, 50 / 60 Hz, 12 Amps
3620920-29	230 VAC, 50 Hz, 6 Amps
3620000-09	115 VAC, 60 Hz, 12 Amps
3620100-09	115 VAC, 60 Hz, 12 Amps
3620110-19	100 VAC, 50/60 Hz, 12 Amps
3620120-29	230 VAC, 50/60 Hz, 6 Amps
3621200-09	115 VAC, 60 Hz, 16 Amps
3621300-09	115 VAC, 60 Hz, 16 Amps
3621310-19	100 VAC, 50/60 Hz, 16 Amps
3621320-29	230 VAC, 50/60 Hz, 8 Amps

Table 2-1

All Purifiers with model numbers ending in –00 to –09 are designed for operation at 115 volts 60Hz, alternating current. Models with numbers ending in –10 to –19 are designed for operation at 100 to 120 volts 50/60Hz. Purifiers with model numbers ending in –20 to –29 are designed for operation at 230 +/- 20 volts, 50/60 Hz alternating current. A dedicated outlet with a circuit breaker rated at 20 amps should be located as close as possible to the right rear side of the cabinet, at a height even with, or higher than, the bottom of the cabinet in its final location.

Note: For 230-volt models, the cord is not equipped with a plug. When installing the user supplied plug always follow the plug manufacturer's instructions for the proper assembly and testing of the plug and power cord.

Note: Both electrical outlets of the 100 and 115 volt purifier are protected by a ground fault interrupter circuit (gfi). Labconco does not recommend plugging the purifier into a gfi outlet.

Service Line Requirements

All service lines to the Purifier should be ¼ inch outside diameter, metal, and equipped with an easily accessible shut-off valve, should disconnection be required. If the service line pressure exceeds 40 PSI, it must be equipped with a pressure regulator to reduce the line pressure.

Note: The use of flammable gases or solvents should be avoided in the Purifier. Open flames in the cabinet will disrupt the laminar airflow in the cabinet and may damage the HEPA filters. Flammable gases or solvents may reach explosive concentrations in the cabinet or ductwork. If you feel that your procedure requires the use of an open flame or flammable materials, contact your institution's safety office.

The use of air or gases under high pressure should be avoided as they may seriously disrupt the airflow patterns in the cabinet.

Chapter 3: Getting Started

Now that the site for your biosafety cabinet is properly prepared, you are ready to inspect, install, and certify your unit. This chapter covers how to:

- Unpack and move your Purifier.
- Set up the cabinet.
- Connect the electrical supply source.
- Connect the service lines.
- Connect to an exhaust system (optional).
- Arrange certification of your Purifier.

Tools required to install your Purifier include, two 1/2" wrenches, a 7/16" wrench, a flat-blade screwdriver, a Phillips screwdriver, and a carpenter's level.

Note: The purifier models weigh between 400 – 700 lbs. (182-318 kg). The carton allows for lifting with a mechanical lift truck or floor jack. If you must lift the purifier manually, use at least six (6) persons and follow safe-lifting guidelines.

Unpacking Your Biosafety Cabinet

Carefully remove the outer carton and inspect it for damage that may have occurred in transit. If your unit is damaged, notify the delivery carrier immediately and retain the entire shipment intact for inspection by the carrier.

Note: The United States Interstate Commerce Commission rules require that claims be filed with the delivery carrier within fifteen (15) days of delivery.

Do not return goods without the prior authorization of Labconco. Unauthorized returns will not be accepted.

If your cabinet was damaged in transit, you must file a claim directly with the freight carrier. Labconco Corporation and its dealers are not responsible for shipping damages.

Do not discard the carton or packing material for your Purifier until you have checked all of the components and installed and tested the unit.

Purifier Components

Labconco manufactures biosafety cabinets with an 8-inch or a 10-inch sash opening. Each of these cabinets is available in a 3-foot, 4-foot and 6-foot model. Models are available in 115V, 100V or 230V. Locate the cabinet model you received in the following table. Verify that the components listed are present and undamaged.

Catalog #	Purifier Description
3620400	3 foot Purifier, 10 inch sash opening, 115 VAC
3620404	3 foot Purifier with UV lamp & fixture, 10 inch sash opening, 115 VAC
3620500	3 foot Purifier, 8 inch sash opening, 115 VAC
3620504	3 foot Purifier with UV lamp & fixture, 8 inch sash opening, 115 VAC
3620510	3 foot Purifier, 8 inch sash opening, 100 VAC 50/60 Hz
3620514	3 foot Purifier with UV lamp and fixture, 8 inch opening, 100 VAC 50/60 Hz
3620520	3 foot Purifier, 8 inch sash opening, 230 VAC
3620524	3 foot Purifier with UV lamp & fixture, 8 inch sash opening, 230 VAC
3620800	4 foot Purifier, 10 inch sash opening, 115 VAC
3620804	4 foot Purifier with UV lamp & fixture, 10 inch sash opening, 115 VAC
3620900	4 foot Purifier, 8 inch sash opening, 115 VAC
3620904	4 foot Purifier with UV lamp & fixture, 8 inch sash opening, 115 VAC
3620910	4 foot Purifier, 8 inch sash opening, 100 VAC 50/60 Hz
3620914	4 foot Purifier with UV lamp and fixture, 8 inch opening, 100 VAC 50/60 Hz
3620920	4 foot Purifier, 8 inch sash opening, 230 VAC
3620924	4 foot Purifier with UV lamp & fixture, 8 inch sash opening, 230 VAC
3620000	5 foot Purifier, 10 inch sash opening, 115 VAC
3620004	5 foot Purifier with UV lamp & fixture, 10 inch sash opening, 115 VAC
3620100	5 foot Purifier, 8 inch sash opening, 115 VAC
3620104	5 foot Purifier with UV lamp & fixture, 8 inch sash opening, 115 VAC
3620110	5 foot Purifier, 8 inch sash opening, 100 VAC 50/60 Hz
3620114	5 foot Purifier with UV lamp and fixture, 8 inch opening, 100 VAC 50/60 Hz
3620120	5 foot Purifier, 8 inch sash opening, 230 VAC
3620124	5 foot Purifier with UV lamp & fixture, 8 inch sash opening, 230 VAC
3621200	6 foot Purifier, 10 inch sash opening, 115 VAC
3621204	6 foot Purifier with UV lamp & fixture, 10 inch sash opening, 115 VAC
3621300	6 foot Purifier, 8 inch sash opening, 115 VAC
3621304	6 foot Purifier with UV lamp & fixture, 8 inch sash opening, 115 VAC
3621310	6 foot Purifier, 8 inch sash opening, 100 VAC 50/60 Hz
3621314	6 foot Purifier with UV lamp and fixture, 8 inch opening, 100 VAC 50/60 Hz
3621320	6 foot Purifier, 8 inch sash opening, 230 VAC
3621324	6 foot Purifier with UV lamp & fixture, 8 inch sash opening, 230 VAC

Plus the Following:

Part #	Component Description
3737100	User's Manual
	Drain Valve Assembly
	Power Cord

If you did not receive one or more of the components listed for your Cabinet, or if any of the components are damaged, contact Labconco Corporation immediately for further instructions.

Moving the Delta

Move the unit by using a floor jack, or a furniture dolly underneath the unit. DO NOT move the cabinet by tilting it onto a hand truck.

After you verify the Purifier components, move your cabinet to its final location.

Preparing the Purifier for Operation

Assembly instructions for the cabinet (Labconco P/N 1056800) are attached to the sash of the Purifier, if these instructions are missing or unclear, contact Labconco at 800-522-7658.

Installing the Purifier On An Existing Work Surface

Note: The Purifier is very top heavy. Use caution when lifting or moving the unit.

When installing the Purifier onto an existing work surface or benchtop, ensure that the structure can safely support the combined weight of the cabinet and any related equipment. The work surface should be at least as wide as the unit and 31 inches deep to properly support the unit.

The work surface should be smooth and durable. The surface should be nonporous and resistant to the disinfectants and chemicals used in conjunction with the Purifier. This will allow a proper seal to form between the bottom of the Purifier and the work surface.

A hole or notch may need to be cut in some work surfaces in the right front corner to accommodate the drain valve.

Installing the Purifier on a Labconco Base Stand

Labconco offers a variety of accessory base stands in a number of configurations to suit your particular needs. Stands can be ordered with preset telescoping legs or, with a manually or electrically adjustable hydraulic lift stand.

Telescoping Base Stands

These stands are available with either fixed feet or caster wheels. The height of these stands is set before installation of the Delta. The height can be set at 27.5 to 33.5 inches in 1-inch intervals, providing a work surface height of 30.0 to 36.0 inches. The Base Stands for each Delta model are listed in Table 3-1 below.

Table 3-1

Width	Delta Series #	Base Stand w/Feet Model #	Base Stand w/wheels Model #
3'	36204-xx, 36205-xx	3730300	3730310
4'	36208-xx, 36209-xx	3730400	3730410
5'	36200-xx, 36201-xx	3830500	3830510
6'	36212-xx, 36213-xx	3730600	3730610

1. Before positioning the Telescoping Base Stand in its final location, adjust the final height of the stand. The height of the work surface can be anywhere between 30 to 36 inches. A part bag containing the mounting bolts for the Purifier is strapped to the base stand. Remove and save it.
2. Select the height of the stand and slide four (4) leg extensions into base stand corner posts and attach with 2 ¼ inch long bolt, flatwasher, lockwasher and nut. Ensure that the same height hole is selected for each leg. Tighten the leg bolts securely. See Figure 3-1.

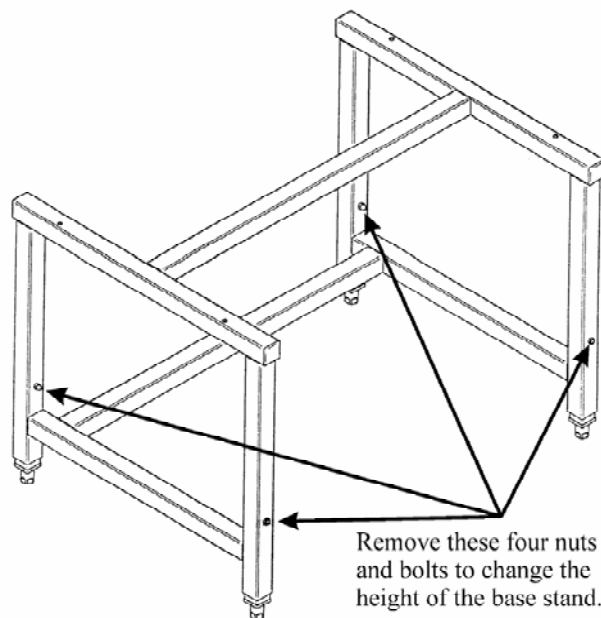

Figure 3-1

3. Move the base stand into its final location. Using a carpenter's level, adjust each leveling foot until the stand is level in both planes as shown in Figure 3-2. You are now ready to lift the Purifier onto its stand.

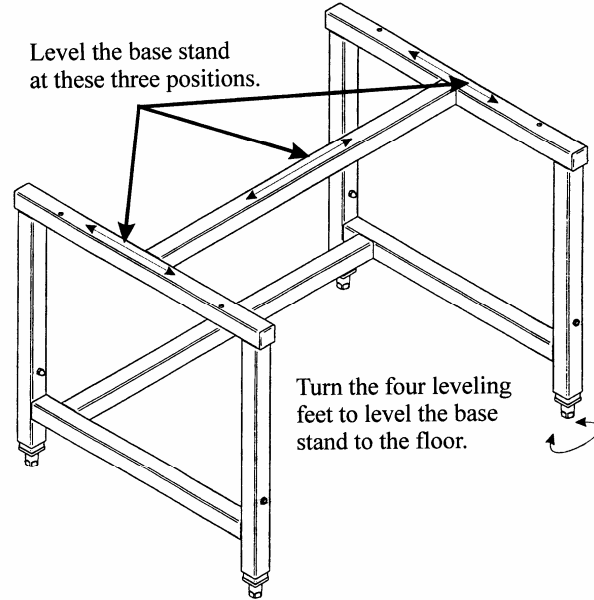

Figure 3-2

Manual or Electric Hydraulic Lift Base Stands

These base stands offer infinitely adjustable height between 25.5 and 33.5 inches, giving a work surface height of 28.0 to 36.0 inches. The height is adjusted either by a manual (hand crank) or electric pump that drives hydraulic rams in the legs of the stands. All of the hydraulic stands are equipped with fixed feet, but can be converted to caster wheels with the addition of Caster Wheel Kit #3784000. The Base Stands for each Delta model is listed in Table 3-2 below.

Table 3-2

Width	Delta Series #	Manual Lift Stand #	Electric (115V) Lift Stand #	Electric (230V) Lift Stand #
3'	36204-xx, 36205-xx	3780200	3780100	3780103
4'	36208-xx, 36209-xx	3780201	3780101	3780104
5'	36200-xx, 36201-xx	3780203	3780106	3780107
6'	36212-xx, 36213-xx	3780202	3780102	3780105

Note: When installing the hydraulic lift base stand, ensure that the hydraulic lines and the electrical cord are clear of any obstructions before installing the cabinet on the stand or operating the lift system.

Connecting The Purifier to Service Lines

The service lines (if any) should be connected to the tube fitting(s) on the outside of the liner wall as shown in Figure 3-3. To install the tubing, follow these steps:

1. Ensure that the tubing is $\frac{1}{4}$ inch outside diameter, soft metal, and that the end has been deburred completely.
2. Route the tubing from the rear of the cabinet, ensuring that it will line up with the slot in the back of the side panel.

Note: Make sure that the tube routing will not contact any electrical wires. Ensure that the tubing will not interfere with the sash weight when the sash is raised or lowered.

3. Make sure that the nut on the tube fitting is loose, but do not remove it. Look inside the fitting to make sure the tube ferrule is there.
4. Push the tube into the fitting until it is properly seated. The tube will go approximately $\frac{3}{4}$ inch into the fitting.
5. Tighten the tube fitting nut hand tight and then, using a $\frac{7}{16}$ -inch wrench, tighten it at least $\frac{3}{4}$ turn more.
6. Close the service valve in the Purifier and then slowly open the shutoff valve on the service valve. Inspect the fitting for leakage. Tighten the tube nut slightly if needed.

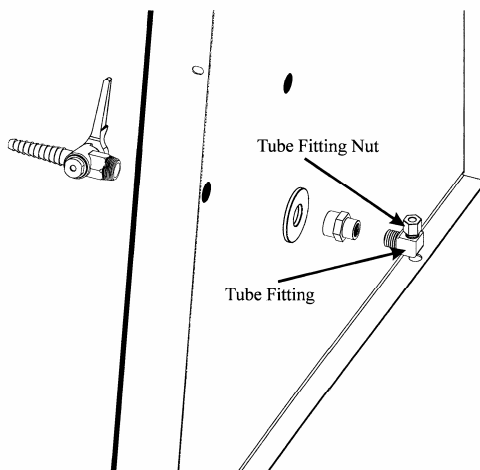

Figure 3-3

Optional Exhaust System Connections

Unless specially modified by Labconco at your request, all Purifier Delta Series Biosafety Cabinets are shipped in the “Type A mode,” meaning they recirculate their HEPA filtered exhaust air back into the laboratory.

Certain applications such as working with odorous products or volatile toxic materials will require the connection of your Purifier to an exhaust system.

Note: The canopy connection, also referred to as a thimble or air gap connection, allows single or multiple biohazard cabinets to be connected to an exhaust system. During operation, the exhaust system draws all of the cabinet’s exhaust air, plus a volume of room air (through the slots in the canopy) into the exhaust duct. Canopy connections function as a “shock absorber” allowing the system to function properly during changes in room air pressure.

For information on selecting and installing a canopy connection go to Chapter 7: Accessorizing Your Cabinet.

To certify the canopy operation, go to Chapter 6: Maintaining Your Cabinet.

Note: If your research involves the use of toxic compounds or volatile materials, contact your facility’s safety officer or Labconco to ensure that your Purifier and its exhaust system are compatible with the materials you will be working with.

Drain Valve Installation

In order to prevent damage during shipping, the drain valve assembly has not been installed in the unit. If desired, the valve should be installed after the unit is in its final location.

To install the valve assembly, follow these steps:

Note: The work surface is heavy. Use caution when handling it.

1. Lift the work surface out of the Purifier by removing the thumbscrews at the front of the work surface and loosening those at the rear of the pan.
2. Using a putty knife, carefully remove and discard the stainless steel cover that is sealed over the drain mounting holes. Scrape out remaining sealant that is around the holes.
3. Apply a light coating of the silicone sealant (user supplied) to the mounting surface of the drain assembly. Attach the drain assembly as shown in Figure 3-4 Wipe off any excess sealant from the cabinet bottom. Ensure that the center drain hole is unobstructed.

4. Make sure the drain valve is in the closed position.
5. Reinstall the work surface.
6. Allow the silicone sealant to cure for at least eight hours before exposing it to liquid.

Figure 3-4

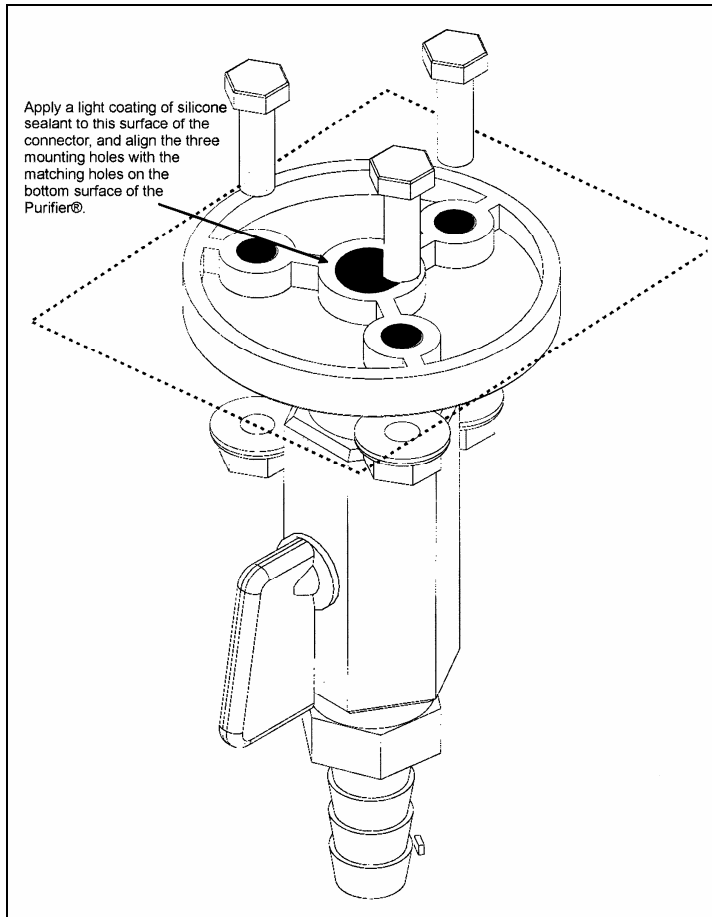

Initial Certification

Prior to use, a qualified certifier should certify all purifier cabinets. Under normal operating conditions, the Purifier cabinet should be recertified at least annually, and when relocated or serviced. The certifier should perform the following tests, as recommended in NSF International Standard Number 49:

- Downflow Velocity Profile Test
- Inflow Velocity Test
- Airflow Smoke Patterns
- HEPA Filter Leak Test
- Vibration Test *
- Noise Level Test *
- Lighting Intensity Test *

*These tests are user comfort related tests and may be omitted at the user's or certifier's discretion.

If you have any questions regarding certification agencies or need assistance in locating one, contact Labconco's Product Service Department at 1-800-522-7658 or 816-333-8811.

Chapter 4: Performance Features and Safety Precautions

All biohazard cabinets operate using the following principles:

- Filtration and retention of particulates by High Efficiency Particulate Air (HEPA) filter(s)
- Laminar airflow (sometimes)
- Directional airflow

The major components in a Biohazard Cabinet are:

- The HEPA filter(s)
- The motor/blower to force air through the unit
- Cabinet air intakes (grilles), ductwork and air balance controls

HEPA Filters

HEPA filters are disposable, dry-type particulate filters. The filter material or media is typically made of borosilicate microfibers formed into a thin sheet, in a process similar to the production of paper. This sheet is folded, or pleated to increase its surface area. The pleats are held in place by aluminum diffusers or by beads of glue that add rigidity to the media pack. The pack is then set into a frame, and sealed as shown in Figure 4-1.

The HEPA filter manufacturer establishes the efficiency of the filter by challenging it with a quantified aerosol of known particle size. The number of particles that penetrate the filter are quantified, and this establishes the efficiency of the filter. Thus, the filters used in the Delta are at least 99.99% efficient in removing particles 0.3 micron.

Note: The HEPA filter media is very fragile. DO NOT touch the media. If you think the media of a HEPA filter is damaged, DO NOT USE THE CABINET. Have the HEPA filter integrity tested by a certifier before using the cabinet.

Note: HEPA Filters are only effective against particulate material. Gases will pass through the filter.

Figure 4-1

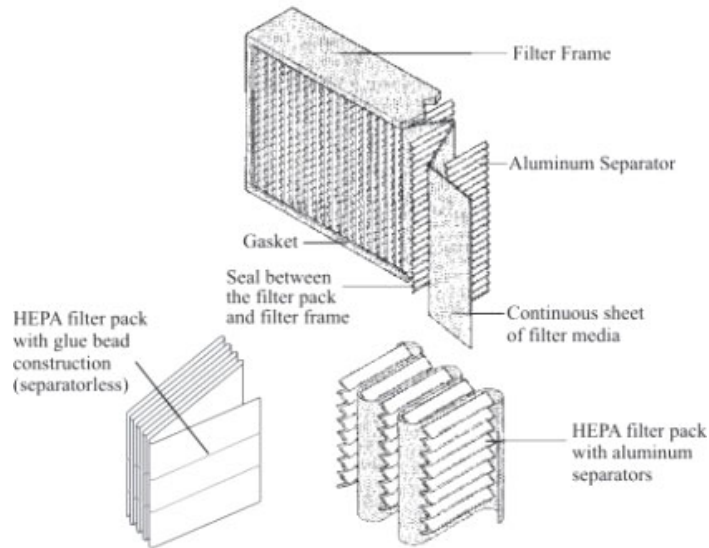

Laminar Airflow

Laminar airflow is defined as the movement of a body of air in a single direction, with a uniform velocity. In practice, the laminar downflow of air in the cabinet captures any aerosol generated in the work area of the cabinet, and directs it to the HEPA filters. In order to be true laminar downflow, a number of individual downflow velocity test points (The Downflow Velocity Profile) must be $\pm 20\%$ of the average of all the test points. This is illustrated in Figure 4-2.

Figure 4-2

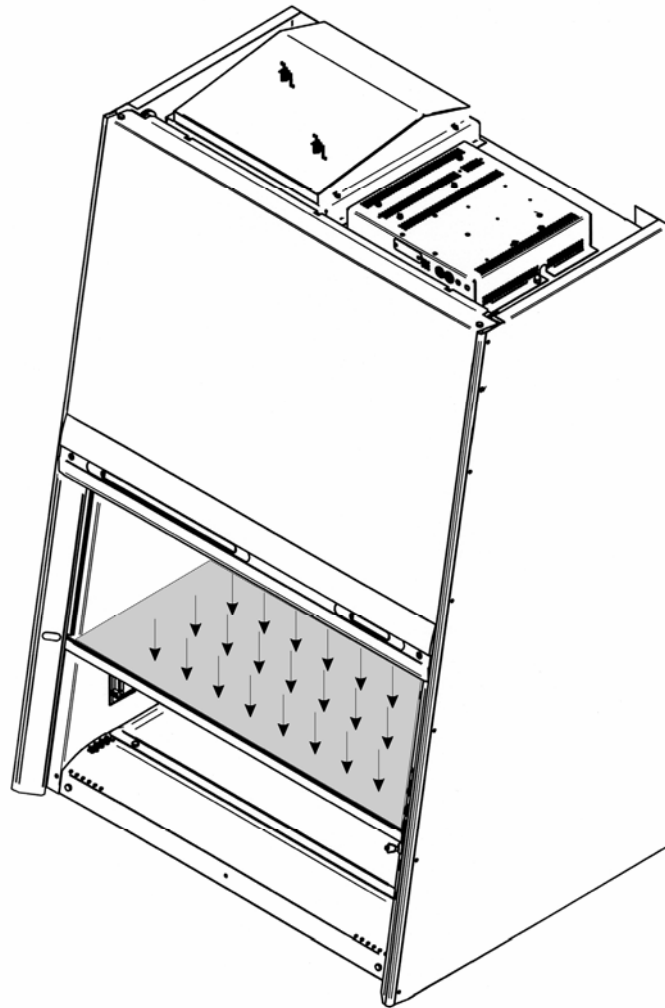

Directional Airflow

Directional airflow also plays a key role in biosafety cabinet performance. Air is drawn into the front of the cabinet at the front grille. This “curtain” of air makes it more difficult for aerosols to escape out of the work area of the cabinet and into the outside environment. This airflow is often calculated and referred to as the

Inflow Volume or **Average Inflow Velocity**. This is illustrated in Figure 4-3.

Figure 4-3

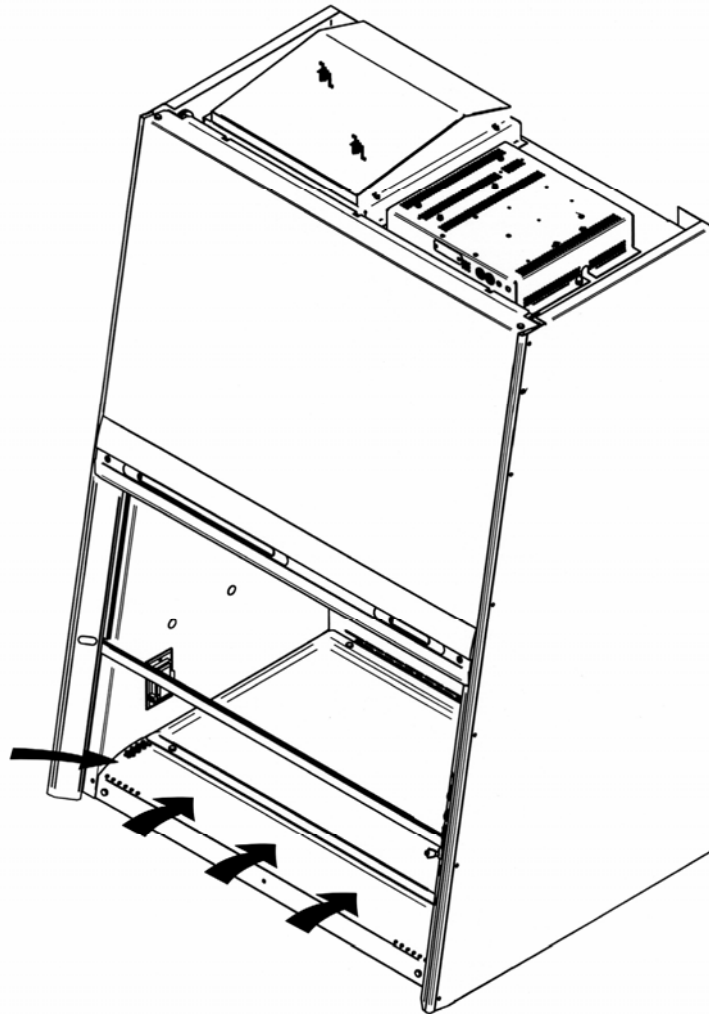

Motor/Blower

The motor/blower assembly pulls air into the front of the cabinet, and recirculates it internally. During its recirculation, the air is split into two separate streams. One path leads through the exhaust HEPA filter and out of the unit. The second path flows through the supply HEPA filter, which then flows down through the work area, as shown in Figure 4:4

Figure 4-4

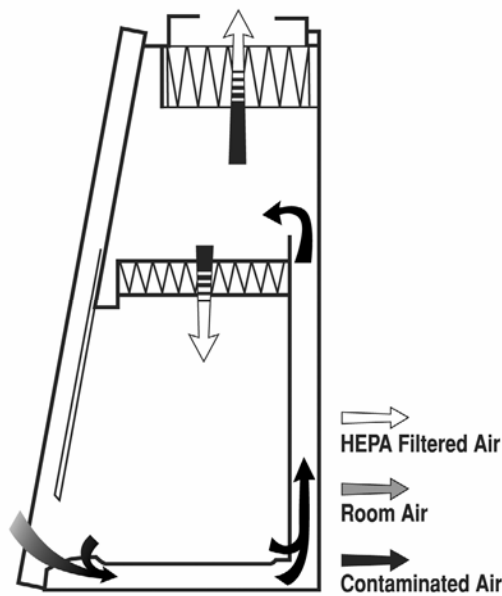

Cabinet Air Intakes (Grilles), Ductwork and Air Balance Controls

The location, size, and pattern of the grilles at the front and rear of the work area affect cabinet containment and performance.

Note: Never block or obstruct the grilles of the Purifier.

The internal ductwork of the Purifier conveys the air from the work area to the blower, and then from the blower to the filters. The positive pressure plenum of the Purifier is unique in the industry, utilizing perfect manifold technology to deliver a more uniform airflow to both HEPA filters, optimizing filter loading and operational life.

Ultraviolet (UV) lamp

The optional UV lamp generates a primary wavelength of light of 254nm. A secondary emission is in the visible (blue) wavelength, resulting in the characteristic blue color while operating. UV light with a wavelength of 254 nm is biocidal, primarily by creating thymine dimers in DNA. These dimers prevent the correct transcription of the DNA into RNA, resulting in cellular death or viral inactivation. In order to be effective, the UV light must directly strike the nucleic acid, and its effectiveness can be diminished or negated by dissolved proteins or metals, or by other UV-opaque substances protecting the target nucleic acid.

Because of its limitations, UV light should be used as an adjunct to good surface disinfection practices. In order to get optimum performance from the UV light, it should be replaced after 6,000 hours of operation or less, and the exterior surface of the lamp should be kept clean and free of dust.

Safety Precautions

The Purifier Biohazard Cabinet should be certified by a certification technician before its initial use. The cabinet should be recertified whenever it is relocated, serviced or at least annually thereafter.

Some internal components of the Purifier may become contaminated during operation of the unit. Only experienced personnel competent in decontamination procedures should decontaminate the cabinet before servicing these components. If you have any questions regarding certification agencies, or need assistance in locating one, contact Labconco's Product Service Department at 800-522-7658 or 816-333-8811.

Ensure that the unit is connected to electrical service in accordance with local and national electrical codes. Failure to do so may create a fire or electrical hazard. Do not remove or service any electrical components without first disconnecting the Purifier from electrical service.

Avoid the use of flammable gases or solvent in the Purifier. Care must be taken to ensure against the concentration of flammable or explosive gases or vapors. An open flame should NOT be used in the Purifier. Open flames may disrupt the airflow patterns in the cabinet, burn the HEPA filter and/or damage the filter's adhesive. Gases under high pressure should not be used in the Purifier cabinet, as they may disrupt the airflow patterns of the cabinet.

HEPA filters only remove particulate matter. Operations generating volatile toxic chemicals or radionuclides must be evaluated carefully.

The media of HEPA filters is fragile and should not be touched. Avoid puncturing either HEPA filter during installation or normal operation. If you suspect that a HEPA filter has been damaged, DO NOT use the cabinet; contact a local certification agency or Labconco at 800-821-5525 or 816-333-8811 for re-certification information.

The HEPA filters in the purifier cabinet will gradually accumulate airborne particulate matter from the room and from work performed in the cabinet. The rate of accumulation will depend upon the cleanliness of the room air, the amount of time the cabinet is operating and the nature of work being done in the cabinet. In typical usage HEPA filters will last approximately five years or more before requiring replacement.

Proper operation of the cabinet depends largely upon its location and the operator's work habits. Consult the Installation and Normal Operation sections of this manual for further details.

Avoid direct exposure of plastic or coated materials to ultraviolet (UV) radiation. Never bypass the UV safety interlock. That only allows the UV light to work when the sash is closed.

When surface disinfecting the purifier:

- Avoid splashing the disinfecting solution on skin or clothing.
- Ensure adequate ventilation.
- Carefully follow the disinfectant's safety instructions
- Always dispose of disinfecting solutions in accordance with local and national laws.
- DO NOT allow disinfectants with high concentrations of free chlorine to contact the stainless steel components of the Purifier for a long period of time. Free chlorine will corrode stainless steel after extended contact.

The electrical receptacle cover may be difficult to surface decontaminate. In the event of gross contamination, the cover should be removed, sterilized and/or decontaminated as required and discarded. The receptacle cover should then be replaced with the repair part listed in Appendix A: Components.

Biohazard cabinets should be decontaminated for any of the following reasons:

- Maintenance work requiring entry into contaminated areas.
- Before HEPA filter changes.
- Before performing certification tests requiring entry into contaminated areas.
- Before relocating the cabinet.
- Before changing research programs.
- After the gross spill of biohazardous material.

The procedures for performing a gaseous decontamination are thoroughly outlined in the U.S. Department of Health, Education and Welfare booklet entitled “Formaldehyde Decontamination of Laminar Flow Biological Safety Cabinets.” which is available from The National Institutes of Health, Division of Safety, Bethesda, Maryland 20892, or from Labconco Corporation.

Chapter 5: Using Your Cabinet

Operating the Sliding Sash

The Purifier's counterbalanced, anti-racking sash mechanism requires only a few pounds of force to move the sash up or down. You can open or close the sash smoothly with one or two hands positioned any where along the handle.

The sash position alarm and safety interlock system senses the sash position and acts appropriately. Your Purifier is designed to operate with either an 8- or 10-inch sash opening, depending on model. Raising the sash above its operating height will activate the audible and visual alarms. The audible alarm can be temporarily muted (for approximately five minutes) by depressing and releasing the alarm silence button. Closing the sash back to its operating position will reset the alarm and defeat the muting of the alarm. The safety interlock system senses when the sash is closed, and will shut off the cabinet blower (to prevent it from overheating). The interlock also allows the optional ultraviolet (UV) lamp to operate only when the sash is closed, to protect the operator from irradiation.

1. To start the Purifier, raise the sash until you feel the sash tactile position indicator (TPI). The TPI functions by increasing the resistance you feel on the sash as it nears its proper operating position. Once in position, the TPI will 'set', requiring additional upward force to be raised further. The correct sash position can be confirmed by aligning the handle of the sash with the indicator decal located on the left side of the opening. The indicator decal is shown in Figure 5-1.

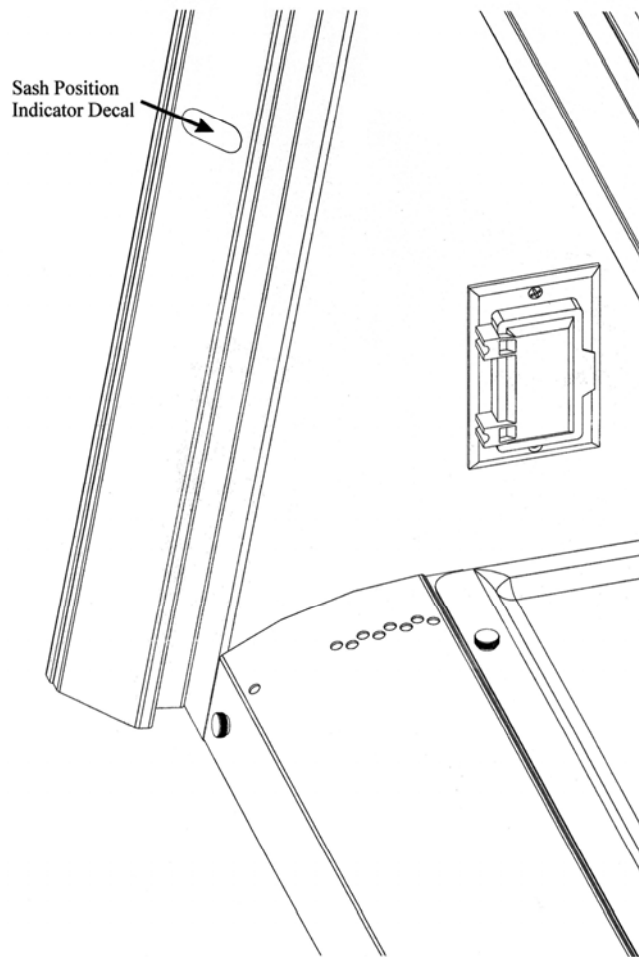
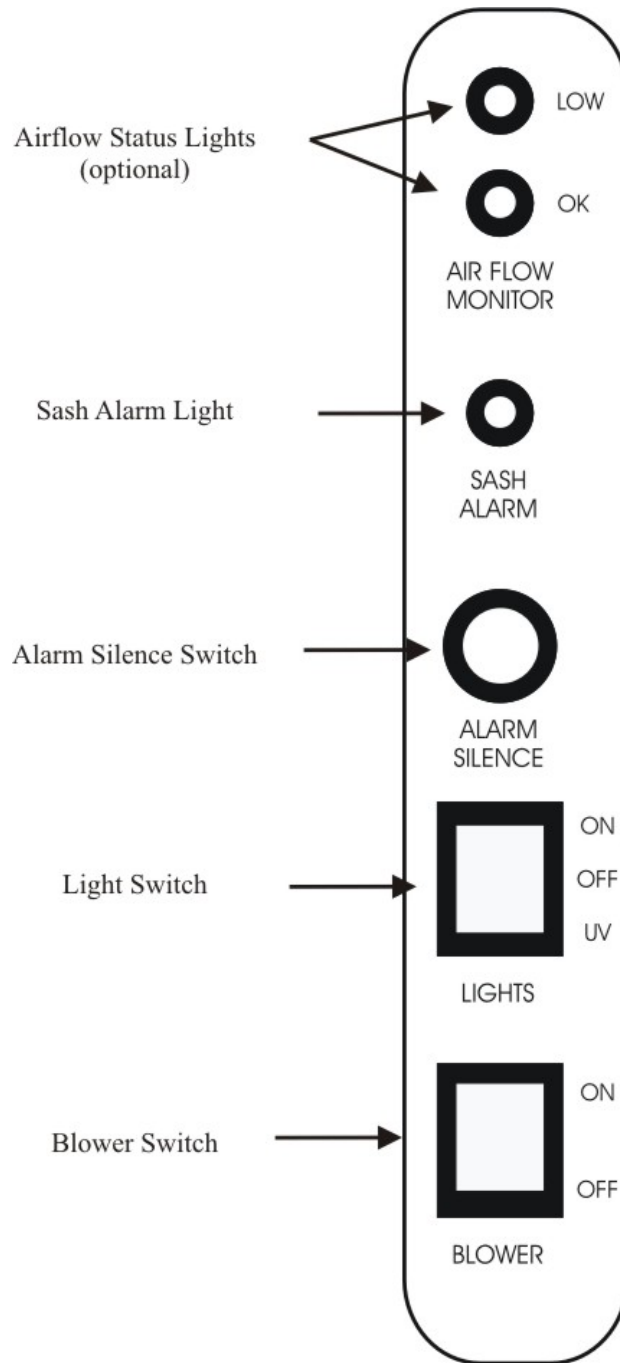

Figure 5-1

2. Turn either the blower or systems switch to the 'On' position, as shown in Figure 5-2. The audible and visual alarms will self-test and be activated for approximately three seconds. The alarms will then shut off. If the alarms continue after three seconds, recheck the sash position. If the sash is too high, the sash audible alarm and the alarm indicator LED will activate.
3. Older model Deltas will automatically turn on their fluorescent light when the 'system power' switch is turned on. For models with a separate light switch, turn the 'lights' switch to the on position.
4. To turn the UV light on, the sash must be completely closed to prevent the escape of any UV radiation. Push either the 'system power' or the 'lights' switch to the UV position to activate the UV light.

The sash must be completely closed for the UV light to activate. When the sash is closed, the Delta's blower(s) will turn off to prevent overheating.

Figure 5-2



Some model Purifier Cabinets are equipped with an optional face velocity alarm system that monitors the volume of air exhausting from the cabinet. If the exhaust volume drops below the minimum requirement, the following occurs:

- An audible alarm sounds.
- The red "Low" indicator light illuminates.

If The Airflow Alarm Activates

The most common causes of alarm activation are:

- Mechanical failure of the cabinet blower.
- Loading of the exhaust HEPA filter.

Note: If the alarm sounds during use, immediately take appropriate action to prevent contamination to you and other personnel in the area.

Resetting The Alarm System

Once the cause of the face velocity alarm has been determined and corrected, the alarm will reset automatically.

Working In Your Purifier

Planning

- Thoroughly understand procedures and equipment required before beginning work.
- Arrange for minimal disruptions, such as room traffic or entry into the room while the cabinet is in use.

Start-up

- Turn off UV light if included.
- Slowly raise the sash until the TPI engages at the proper height. Confirm the sash is at its proper height by examining the sash indicator decal located on the left side of the work area.
- Turn on fluorescent light and cabinet blower.
- Check the air grilles for obstructions, and note the pressure gauge reading.
- Allow the cabinet to operate unobstructed for 5 minutes.
- Wash hands and arms thoroughly with germicidal soap.
- Wear a long sleeved lab coat with knit cuffs and over-the-cuff rubber gloves. Use protective eyewear. Wear a protective mask if appropriate.

Wipe-Down

- Raise the sash to its full open position (approximately 19 inches open). Mute the alarm by depressing the "Alarm Silence" switch.
- Wipe down the interior surfaces of the cabinet with 70% ethanol, or a suitable disinfectant, and allow to dry.

Loading Materials and Equipment

- Only load the materials required for the procedure. Do not overload the cabinet.
- Do not obstruct the front, side, or rear return air grilles.
- Large objects should not be placed close together.
- Slowly close the sash until the TPI is engaged correctly.
- After loading the cabinet, wait two to three minutes to purge airborne contaminants from the work area.

Work Techniques

- Keep all materials at least 4 inches inside of the sash, and perform all contaminated operations as far to the rear of the work area as possible.
- Segregate all clean and contaminated materials in the work area.
- Arrange materials to minimize the movement of contaminated materials into clean areas.
- Keep all discarded contaminated material to the rear of the work area.
- Avoid moving materials or the operator's hands and arms through the front access opening during use.
- Avoid the use of an open flame.
- Use proper aseptic technique.
- Avoid using techniques or procedures that disrupt the airflow patterns of the cabinet.
- If there is a spill or splatter during use, all objects in the cabinet should be surface decontaminated before removal. Thoroughly disinfect the working area of the cabinet WHILE IT IS STILL IN OPERATION. This will prevent the release of contaminants from the cabinet.

Final Purging

- Upon completion of work, the cabinet should be allowed to operate for two to three minutes undisturbed, to purge airborne contaminants from the work area.

Unloading Materials and Equipment

- Objects in contact with contaminated material should be surface decontaminated before removal from the cabinet.
- All open trays or containers should be covered before being removed from the cabinet.

Wipe-Down

- Wipe down the interior surfaces of the cabinet with 70% ethanol, or a suitable disinfectant, and allow to dry.
- Periodically lift the work surface and wipe down the area beneath it.
- Inspect and clean the towel catch located at the rear of the work area, beneath the work pan.
- Dispose of rubber gloves appropriately, and have lab coat laundered properly.
- Wash hands and arms thoroughly with germicidal soap.

Shutdown

- Turn off the fluorescent light and cabinet blower, close the sash, and turn on the UV light if appropriate.

Safety and Comfort

Many factors in our work environment determine whether we work efficiently and in a manner that promotes good health and safety. By considering, acting on, and periodically reevaluating the recommendations in this section, it is possible to create a safer, more comfortable, healthful, and efficient work environment.

Note: Working intensely or for a long time in uncomfortable or unnatural positions poses risks.

Organizing Your Adjustments

The order in which you make various adjustments to your body position and work area may vary depending on the adjustability of your furniture. Labconco offers an optional ergonomic chair and adjustable footrest for further information see Appendix D: Accessories.

Pay particular attention to adjusting your posture in the afternoon when you may tend to get fatigued.

When you reposition any one part of your body, you may need to adjust other parts as well.

Note: Don't sit in one fixed posture all day.

Feet, Knees, and Legs

Make sure your feet can rest solidly and comfortably on the floor or footrest while sitting. Use an adjustable chair that allows your feet to rest firmly on the floor, or use a footrest. If you use a footrest, be sure it is wide enough to accommodate different leg positions within your comfort zone.

- Rest your feet firmly on the floor or a footrest.
- Don't dangle your feet and compress your thighs.

Providing Enough Leg Room

- Be sure you have sufficient space under your work surface for your knees and legs. Avoid concentrated pressure points along the underside of your thigh near the knee and the backside of your lower leg. Stretch your legs and vary your leg posture throughout the day.

Leg Comfort

- Vary your leg positions throughout the day.
- Avoid placing boxes or other items under the cabinet that limit your legroom. You should be able to pull your chair all the way up to your Purifier without interference.

Walk

Get up from your Purifier periodically and take brief walks.

Back

Use your chair to fully support your body. Distribute your weight evenly and use the entire seat and backrest to support your body. If your chair has adjustable low back support, match the contours of the chair's backrest to the natural curve of your lower spine. Always make sure your lower back is well supported. Make sure it feels comfortable in the position in which you are working.

- Distribute your weight evenly and use the entire seat and backrest to support your body.
- Don't slouch forward.

Adjust often

- If your chair is adjustable, experiment with the adjustments to find numerous comfortable positions, then adjust the chair frequently.
- If you are using a chair for the first time, or if you share a chair with someone else, don't assume the settings are properly set for you.

Forearms, Wrists, and Hands

- Keep your forearms, wrists, and hands aligned in a straight, natural position. Avoid bending or angling your wrists while working.

Don't Anchor Your Wrists

- When working, do not anchor or rest your wrists on the work surface. Resting your palms while working may be harmful because it can cause you to bend your wrists back and can apply pressure to the undersides of your wrists.
- Maintain a straight, natural wrist position while working.

Shoulders and Elbows

- Adjust your chair height or Purifier height so that your shoulders are relaxed and your elbows hang comfortably at your sides.

Relax

- Remember to relax, particularly in areas where muscle tension often builds, such as your shoulders.

Eyes

- Working at your Purifier for long periods can be a visually demanding task and may cause your eyes to become irritated and fatigued. Give special attention to vision care, including the following recommendations:

Resting Your Eyes

- Give your eyes frequent breaks. Periodically look away from the work area and focus at a distant point. This may also be a good time to stretch, breathe deeply, and relax.

Cleaning Your Sash and Glasses

- Keep your sash and glasses clean.

Having Your Eyes Examined

- To be sure that your vision is adequately corrected, have your eyes examined regularly by a vision care specialist.
- If you wear bifocals or trifocals, you may find monofocal glasses more comfortable for cabinet use.

Eye comfort

- While working in your Purifier, and also while resting your eyes, remember to blink. This helps keep your eyes naturally protected and lubricated, and helps prevent dryness, a common source of discomfort.
- Give your eyes frequent rests by focusing them on a distant point.

Arranging Your Work Area

Eliminating Glare and Reflections on the Sash

- Take the time to eliminate glare and reflections. To control daylight, use blinds, shades, or drapes, or try other glare-reducing measures. Use indirect or reduced lighting to avoid bright spots on the sash. If glare is a problem, consider these actions:
- Turn off or reduce ceiling lights and use task lighting (one or more adjustable lamps) to illuminate your work.
- Avoid compromising your posture to compensate for glare or reflections.

Positioning Work Materials

- Position work materials directly in front of you to avoid twisting your neck and torso. This makes it possible to work with your shoulders relaxed and your upper arms hanging freely at your sides.

Minimizing Your Reach

- Arrange your frequently used materials to minimize the distance you reach for them.

Hand Manipulation

- Notice how you use your fingers and hands while working. Avoid keeping any unnecessary tension in your thumbs and fingers. Observe whether you have a heavy touch or a light touch while working.

Reaching for Materials

- To reach material that is not near your hands, move your whole arm; avoid stretching your fingers and angling your wrists.
- Relax your thumbs and fingers while working; notice and release excess tension.
- Don't work with unnecessary tension in your thumbs and fingers.

Wrist Position

- Use your whole arm and shoulder to move objects, not just your wrist. Don't rest or anchor your wrist while moving items; keep your wrist, arm, and shoulder free to move.

Aligning Forearms, Wrists, and Hands

- When working in the Purifier, keep your forearms, wrists, and hands comfortably aligned with each other in a straight, natural line. Avoid bending or angling your wrists.

Taking Breaks and Varying Your Tasks

- As noted earlier, your furniture placement, lab equipment, and lighting are only a few of the factors that determine comfort. Your work habits are also very important. Remember the following:
- Take breaks.
- When you work at your Purifier for long periods, take short breaks at least once per hour and preferably more often. You may find that frequent, short breaks will benefit you more than fewer, longer breaks.
- If you find that you forget to take breaks, use a timer.
- During your breaks, stand up and stretch, especially any muscles and joints you may have held in an extended static posture while working.

Vary Your Tasks

- Examine your work habits and the types of tasks you perform. Break up the routine and try to vary your tasks during the day. By doing so, you may avoid sitting in one position or performing the same activities continuously for several hours using your hands, arms, shoulders, neck, or back.

Reduce Sources of Stress

- Take an inventory of things at work that are stressful to you. If you perceive that your physical or psychological health is being affected, take time to evaluate what changes you can make to reduce or eliminate the sources of stress.
- Breathe fresh air deeply and regularly. The intense mental concentration that may accompany work in a Biosafety Cabinet may tend to cause breath-holding or shallow breathing.

Self-Check

- To increase your comfort and reduce potential safety risks, use this checklist to help you evaluate your work posture and habits.

Seated Position

- Have you found a range of seated postures that are most comfortable for you?
- Are you changing postures within your "comfort zone" throughout the day, especially in the afternoon?
- Are your feet firmly planted?
- Are the undersides of your thighs near your knees free of pressure?
- Are the backs of your lower legs free of pressure? Is there sufficient space under your cabinet for your knees and legs?
- Is your lower back supported?

Shoulders, Arms, Wrists, and Hands

- Are your shoulders relaxed?
- Are your hands, wrists, and forearms aligned in a straight, natural position?
- Are your elbows in a relaxed position near your body?
- Are items you use frequently easy to reach?

Eyes

- Do you rest your eyes frequently by focusing on a distant point?
- Do you get your eyes examined regularly by a vision care specialist?
- Do you blink enough?
- If you wear bifocals or trifocals, do you avoid tilting your head back to see your work?

Working Style

- Are you training your fingers to relax when they become tense?
- Do you use your whole arm to reach for objects not located near your fingers?
- Is your work positioned directly in front of you?
- Are your wrists straight and your shoulders relaxed?
- Have you eliminated glare and bright reflections on the sash, without compromising your posture?

General Prevention

- Do you take breaks and walk around briefly, preferably once per hour?
- Do you exercise regularly?
- Periodically, do you take inventory of the stress in your life and change what is within your control to change?

Chapter 6: Maintaining Your Cabinet

Now that you have an understanding of how to work in the Purifier, we will review the suggested maintenance schedule and the common service operations necessary to maintain your Purifier for peak performance.

Note: Many of the service operations should be performed only by trained and experienced certification technicians after the cabinet has been properly decontaminated. DO NOT attempt to perform these operations if you are not properly trained. The wrench icon precedes the service operations that require qualified certifiers.

Routine Maintenance Schedule

Weekly

- Using 70% ethanol, or a suitable disinfectant, surface disinfect the inside of the cabinet, and the work surface.
- Using an appropriate glass cleaner, clean the sash and the surface of the UV lamp, if so equipped.
- Operate the cabinet blower, noting the pressure reading in an operational log.

Monthly (or more often as required)

- Using a damp cloth, clean the exterior surfaces of the cabinet, particularly the front and top of the cabinet, to remove any accumulated dust.
- Disinfect and lift the work surface. Surface disinfect the lower plenum with a solution of 70% ethanol, or a suitable disinfectant. Check the towel catch for retained materials.
- Check all service valves, if so equipped, for proper operation.
- All weekly activities.

Annually

- Have the cabinet re-certified by a qualified certification technician.
- Replace the UV lamp, if so equipped.
- All monthly activities.

Biannually

- Replace the fluorescent lamp.

Service Operations

Work Surface Removal:

Note: The work surface of the cabinet must be thoroughly decontaminated before removing it.

1. Loosen and remove the thumbscrews located at the front of the work surface, as shown in Figure 6-1.
2. ***Only loosen*** the thumbscrews located at the rear of the work surface.
3. Lift the front edge of the work surface up and pull it out of the cabinet work area.

Towel Catch Removal:

Although not normally required, the towel catch can be removed for cleaning, inspection, etc.

Note: The work surface of the cabinet and the towel catch must be thoroughly decontaminated before removing either.

1. Remove the work surface as described above.
2. Loosen and remove the thumbscrews located at the rear of the work surface.
3. Surface decontaminate the towel catch before removing it.

Figure 6-1

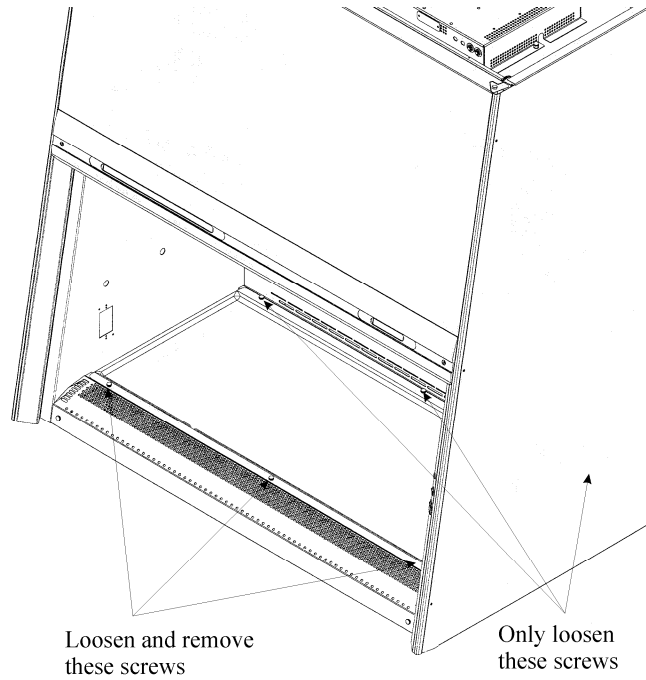

Front Panel Removal:

1. Locate and remove the two Phillips screws that secure the front panel as shown in Figure 6-2.
2. Swing the bottom of the dress panel out to clear the fluorescent light and then lift the front dress panel straight up and away from the cabinet.

Figure 6-2

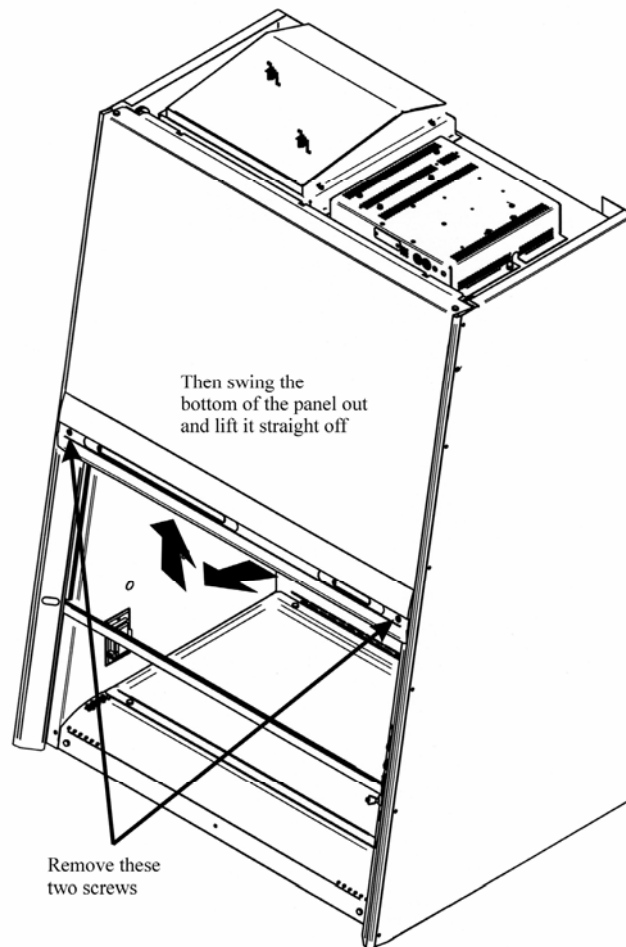

Changing the Fluorescent Lamp for 3', 4' and 5':

1. Unplug the cabinet.
2. Remove the front dress panel as noted in Figure 6-2.
3. Remove the fluorescent lamp by rotating it 90 degrees and pulling it straight up and out of its sockets.
4. Install the new lamp by reversing the removal procedure.

Changing the Fluorescent Lamp for 6':

1. Unplug the cabinet.
2. Remove the front dress panel as noted in Figure 6-2.
3. Remove the fluorescent lamp by pushing it to the left and swinging it out of the right lamp socket.
4. Install the new lamp by reversing the removal procedure.

Changing the Optional UV Lamp for 3', 4' and 5':

Note: For optimum performance, the UV lamp should be changed on an annual basis.

The UV lamp and the work area of the cabinet must be thoroughly decontaminated before removing the lamp.

1. Start the cabinet and let it operate for 5 minutes.
2. Raise the sash to its full open position.
3. Thoroughly surface decontaminate the UV lamp and the work area of the cabinet.
4. Unplug the cabinet.
5. Remove the UV lamp by rotating it 90 degrees and lifting it straight up and out of its sockets.
6. Install new lamp by reversing the removal procedure.

Changing the Optional UV Lamp for 6':

For optimum performance, the UV lamp should be changed on an annual basis.

The UV lamp and the work area of the cabinet must be thoroughly decontaminated before removing the lamp.

1. Start the cabinet and let it operate for 5 minutes.
2. Raise the sash to its full open position.
3. Thoroughly surface decontaminate the UV lamp and the work area of the cabinet.
4. Unplug the cabinet.
5. Remove the UV lamp by pushing it to the left and swinging it out of the right lamp socket.
6. Install new lamp by reversing the removal procedure.

Resetting a Circuit Breaker:

To reset any of the circuit breakers located on the front of the electronics module, depress the white button until it sets.

Note: A qualified certifier should only perform the service operations listed in the rest of this chapter.

Downflow Velocities

The average downflow velocity for all model Purifiers should be set to match the data plate on the front of the unit.

Downflow Velocity Grid Patterns

The downflow velocity test grid pattern for all model Purifiers is listed on the data plate on the front right side of the grille. If the label is missing or obliterated, contact Labconco AT 1-800-522-7658.

Inflow Velocity Calculation - Primary Method

The average inflow velocity for all Purifiers is 105 ±5 FPM, and should be determined by converting the inflow volume to the average inflow velocity. The inflow volume is measured directly by sealing a direct inflow measuring flowmeter to the face of the unit. When corrected for local conditions, dividing the inflow volume by the opening area will yield the average inflow velocity.

Table 6-1

Purifier Model	Sash Height (inches)	Avg. Inflow Velocity (FPM)	Work Opening Area (sq. ft.)	Inflow Volume (CFM)
3620400	10	105 ±5	2.53	253-278
3620500	8	105 ±5	2.03	203-223
3620800	10	105 ±5	3.37	337-370
3620900	8	105 ±5	2.69	269-296
3620000	10	105 ±5	4.20	420-462
3620100	8	105 ±5	3.36	336-370
3621200	10	105 ±5	5.03	503-554
3621300	8	105 ±5	4.03	403-443

Inflow Velocity Calculation - Secondary Method

If the primary method cannot be performed, the secondary inflow calculation method should be performed. The secondary method uses a hot wire thermal anemometer. In this method, the sash is lowered until the open area of the sash equals one square foot, and a series of velocity readings are taken at the front of the unit.

1. For each model Purifier, the sash should be closed until the distance from the bottom edge of the sash to the bottom edge of the airfoil equals “A” as shown below. The thermal anemometer probe should be positioned such that the center of the sensor is “B” above the bottom edge of the airfoil as shown below. This will place the center of the probe at the center of the restricted opening.

Table 6-2

Purifier Models	A Dimension	B Dimension
3-foot, 36204, 36205	6 1/16"	4 1/32"
4-foot, 36208, 36209	4.8"	3.3"
5-foot, 36200, 36201	4 1/2"	3 1/4"
6-foot, 36212, 36213	4 1/8"	3 1/16"

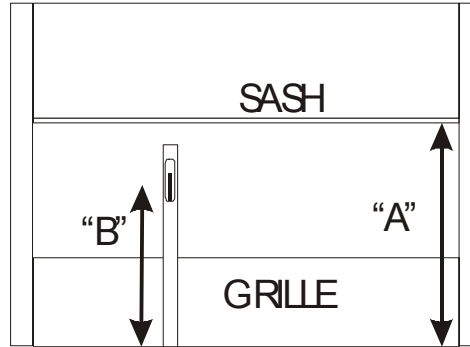

2. Start the Purifier, and let it operate for at least 5 minutes.
3. Establish the necessary correction factor to the thermal anemometer to ensure compliance with its performance in a calibrated wind tunnel. This data should be available from the calibrator of the thermoanemometer.
4. Calculate the manufacturers recommended correction factor(s) to correct for local conditions of temperature, humidity, barometric pressure, altitude, etc.
5. Measure a number of test points, 4 inches from each side wall, and at intervals of the following distance for each of these models:

Table 6-3

Model Numbers	Distance Between each Test Point (inches)	Total Number of Test Points
36200, 36201	4.04	14
36204, 36205	4.07	8
36208, 36209	4.05	11
36212, 36213	4.03	17

6. Take a series of inflow velocities by placing the sensor of the thermal anemometer at the test points, in the center of the opening, leaning the body of the probe against the front of the grille.
7. Apply the wind tunnel correction and local condition correction factors to the thermal anemometer readings.
8. Multiply the individual readings by the following Purifier correction factor:

Model Numbers	Purifier Correction Factors (CFM/FPM)
36204*	1.08
36205*	1.06
36208	1.13
36209	1.12
36200	1.25
36201	1.25
36212	1.30
36213	1.24

Average the corrected readings.

*On models with serial #99xx, 0001 through 0007, the correction factor for model 36204 is 1.13 and for 36205 is 1.11.

Table 6-4

- The resulting value is the inflow volume in cubic feet per minute (CFM). In order to convert this value to the average inflow velocity of feet per minute (FPM), divide the volume by the sash open area given in Table 6-5 below.

Table 6-5

Model Numbers	Sash Open Area (square feet)
36204	2.53
36205	2.03
36208	3.37
36209	2.69
36200	4.20
36201	3.36
36212	5.03
36213	4.03

- The resulting value will be the calculated average inflow velocity in FPM.

Calibration of the Type A2 Inflow Alarm

Some Delta Type A2 models are equipped with a flow switch located on the exhaust cover and two indicator LEDs on the control panel. To calibrate the flow alarm do the following:

- Ensure the flow switch is installed and operational.
- Allow the Delta unit to operate for at least 10 minutes.
- Referring to the Table 6-6, adjust the inflow volume to the alarm set point volume for the model being tested. The alarm should not sound.

4. **If the “LOW” LED is on and the audible alarm is sounding:**
Remove the flow switch cable housing, located to the right of the flow switch. Using a small screwdriver, turn the flow switch adjustment screw located on the end of the switch near the wiring clockwise (facing the screw), as shown in Figure 6-3. Reposition the housing to its original position. Repeat this procedure until the red “LOW” LED goes out the green airflow monitor “OK” LED illuminates, and the audible alarm does not sound WITH THE CABLE CONNECTOR HOUSING IN PLACE.

If the “OK” LED is on: Remove the flow switch cable housing, located to the right of the flow switch. Use the screwdriver to turn the adjustment screw on the flow switch counterclockwise (facing the screw). Reposition the housing to its original position. Repeat this procedure until the “LOW” airflow LED lights and the audible flow alarm sounds.

5. Adjust the exhaust volume to the nominal value in the table below. The red “LOW” LED goes out and the “OK” green LED is illuminated and the audible alarm turns off.

Figure 6-3

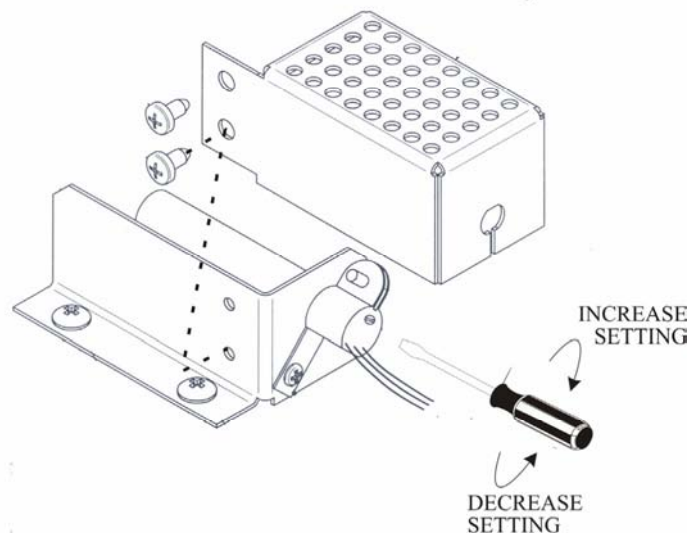

Table 6-6

Model	Alarm set point volume (CFM) (=90 FPM Avg. Inflow)	Nominal volume (CFM) (=100-110 FPM Inflow)
36204	228±5	253-278
36205	183±5	203-223
36208	303±5	337-370
36209	242±5	269-296
36200	378±5	420-462
36201	302±5	336-370
36212	453±5	503-554
36213	363±5	403-443

Calibration of the Type B3 Face Velocity Alarm

Note: Type B3 exhaust systems were available on Delta cabinets manufactured through 2003.

A qualified certification technician should calibrate the Face Velocity Alarm. The alarm switch is set at the factory at its lowest pressure setting and it will need to be calibrated before using the Purifier.

Figure 6-4

1. Set the exhaust damper so that the exhaust volume is at the alarm setpoint as indicated in Table 6-7, and mark the damper position.
2. With the Purifier running, turn the adjusting screw, as shown in Figure 6-4 very slowly clockwise (increasing the pressure setting) until the alarm is activated. This is the alarm setpoint.
3. Confirm the alarm operation by opening the damper slightly and pressing the “Alarm Silence” switch. The cabinet will operate normally. While the cabinet is running, slowly return the damper to its setpoint. If the alarm does not sound at the setpoint, repeat steps 2 and 3 until proper operation is obtained.

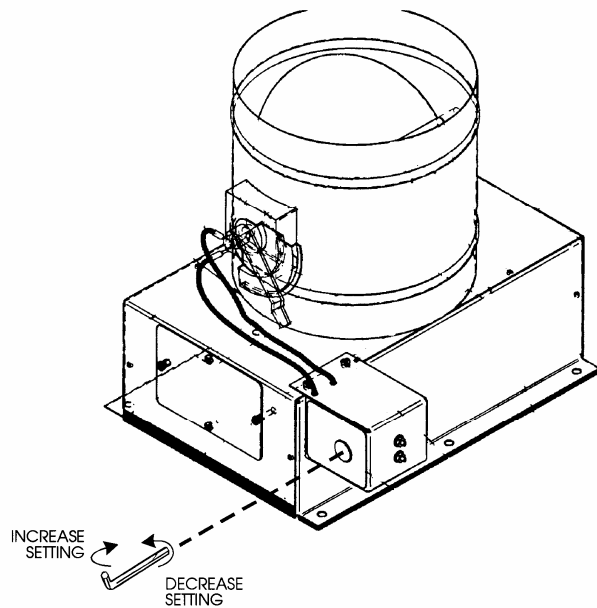

4. Open the exhaust damper until the exhaust volume is at the normal exhaust volume, as indicated in Table 6-7.
5. With the exhaust volume set, the downflow can be established.

Table 6-7

Purifier Airflow Data				
Model Number	Average Inflow Velocity (FPM)	Work Opening Area (sq. ft.)	Exhaust Volume of Cabinet (CFM)	Alarm Setpoint Volume (CFM)
36204-0x	105	2.53	253-278	228 ±5
36205-0x	105	2.03	203-223	183±5
36205-1x	105	2.03	203-223	183 ±5
36205-2x	105	2.03	203-223	183 ±5
36208-0x	105	3.37	337-370	303 ±5
36209-0x	105	2.69	269-296	242 ±5
36209-1x	105	2.69	269-296	242 ±5
36209-2x	105	2.69	269-296	242 ±5
36212-0x	105	5.03	503-554	453 ±5
36213-0x	105	4.03	403-443	363 ±5
36213-1x	105	4.03	403-443	363 ±5
36213-2x	105	4.03	403-443	363 ±5

Electronics Module Access

Note: A qualified certification technician should service the electronics module assembly.

The electronics module houses the speed control, the lamp ballasts, the circuit breakers, as well as the motor capacitor.

1. Unplug the cabinet.
2. Remove the two 7/16" acorn nuts that secure the electronics module to the top of the cabinet, shown in Figure 6-5.
3. Pivot the module onto its back surface to access the electronic components within.

Figure 6-5

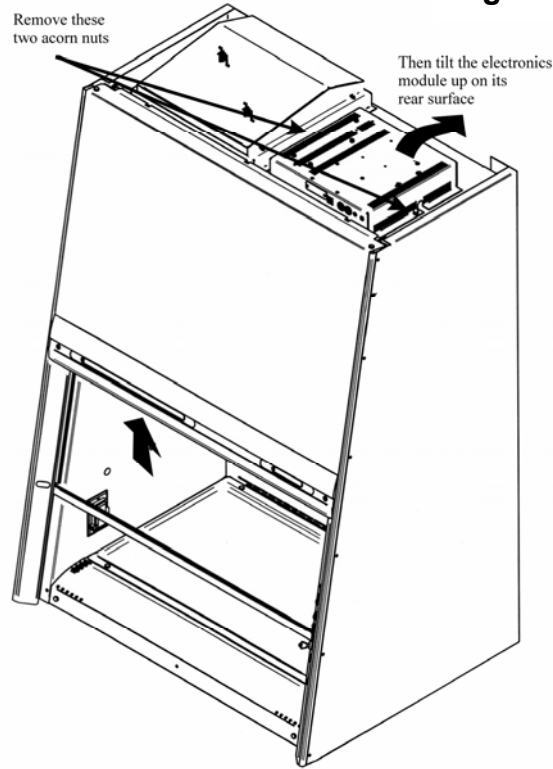

Measuring Line and Motor Voltage

Line and motor voltage contact points are high voltage connections. Use caution when measuring either voltage.

A voltage connector can be fabricated from commercially available electronics hardware, or one is available to qualified certifiers from Labconco Corporation. Contact Labconco's Product Service Department for further details.

1. Remove the access panel located on the front of the electronics module by removing the right hand Phillips screw, and loosening the left hand screw as shown in Figure 6-6. Pivot the panel out of the way.
2. Locate the voltage test points on the electrical panel. Figure 6-7, shown below, identifies the test points.
3. Using a voltmeter and probes, measure the desired voltage by connecting the voltmeter probes to the appropriate points.

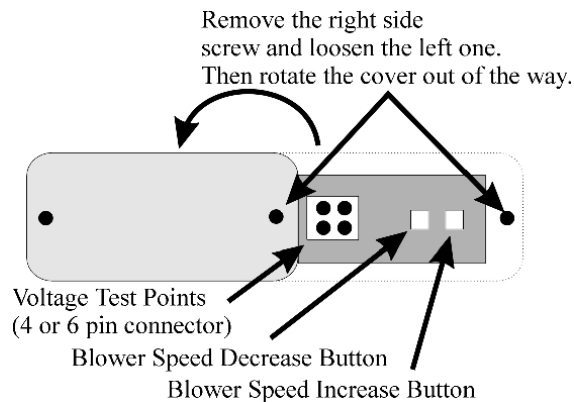

Figure 6-6

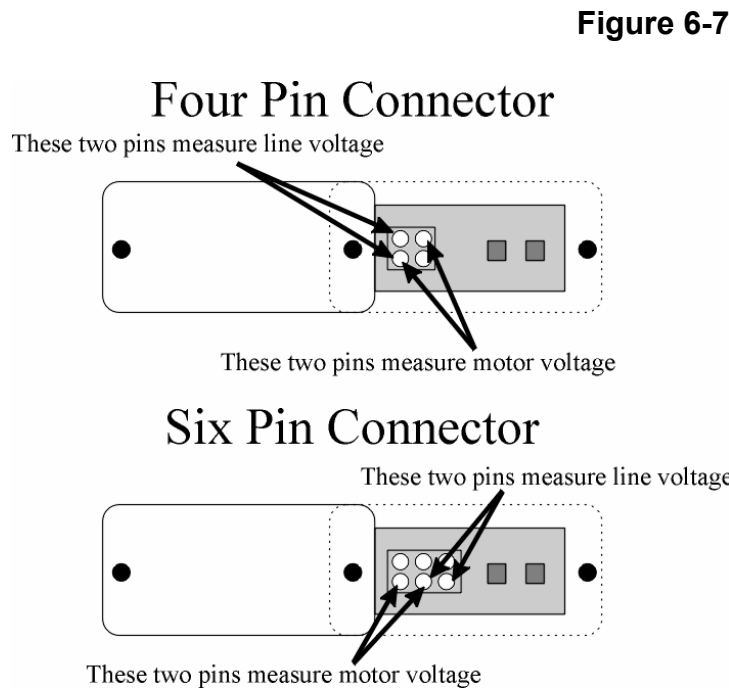

Figure 6-7

Speed Control Adjustment

Note: A qualified certification technician should only adjust the Purifier blower speed. Adjustment of the blower speed will affect the containment efficiency of the unit.

Note: The Purifier's blower speed is adjusted and a solid-state electronic circuit maintains its setpoint. There is no potentiometer as on traditional biosafety cabinets. The blower speed setting is adjusted and protected by an electronic interlock that must be released to reset the motor voltage.

1. Remove the access panel located on the front of the electronics module by removing the right hand Phillips screw, and loosening the left hand screw as shown in Figure 6-6. Pivot the panel out of the way.
2. Locate the voltage test points on the electrical panel. Figure 6-7 identifies the test points.
3. Using a voltmeter and probes, measure the motor voltage by connecting the voltmeter probes to the appropriate points.
4. Shut the Purifier off.
5. While holding down the "alarm silence" button, turn the "System Power" switch on.
6. The blower will start, and the audio and visual alarm will operate in an alternating mode. The blower speed can now be adjusted.
7. Pressing the button on the right can increase the blower speed; pressing the button on the left decreases the blower speed as shown in Figure 6-6.
8. Once inflow and downflow testing have established the proper blower speed, the new blower voltage can be programmed into the speed controller by depressing the "Alarm Silence" button again. The audio alarm will sound a single long tone, and then shut off, indicating the new voltage is properly programmed.

Note: If you wish to cancel the new blower voltage setting, simply turn the "system Power" switch off before depressing the "alarm silence" button. This will cancel the new setting, and return the speed controller to its previous value.

Exhaust Control System Adjustment

Note: Adjusting the exhaust control system will have an effect on the air velocities and the efficiency of the cabinet. A certification technician as part of the recertification procedure should only adjust the exhaust control system.

Some early 3-foot wide Purifiers with serial numbers beginning in 99xx or 0001 through 0007, were equipped with a single piece, orange exhaust cover. As shown in Figure 6-8.

1. Locate the exhaust filter cover located on the top of the cabinet.
2. To increase the flow of exhaust air, remove one or more of the exhaust hole plugs. The plugs "lock" into the cover. To remove the plug, reach through an adjacent hole, and depress the tabs that secure the plug into the cover.
3. To decrease the exhaust flow, insert one or more plugs back into the vacant holes in the exhaust cover. Additional plugs are stored in the parts bag shipped with the cabinet.
4. Reestablish the inflow, making sure it meets the specification mentioned in Table 6-1.

Figure 6-8

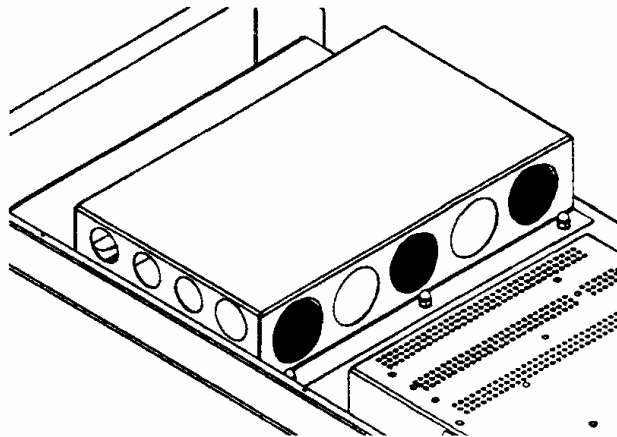

If you need additional exhaust control system plugs, contact Labconco's Product Service Department.

Later 3-foot units, as well as all 4-foot and 6-foot wide Purifiers manufactured through October 2003 utilize a two-piece exhaust cover system shown in Figure 6-9.

1. Remove the four nuts that secure the orange exhaust diffuser cover from the top of the Purifier.

Do not remove or attempt to adjust the angled deflector blades on the primary exhaust cover.

2. To increase the exhaust flow, remove blocking strip(s) from the primary exhaust cover, install them in the storage areas at the front or rear of the cover. Reinstall the exhaust diffuser cover.
3. To decrease the exhaust flow, remove surplus blocking cover strip(s) from the front or back storage area, and install them over an open row of holes. Reinstall the exhaust diffuser cover.
4. Reestablish the inflow, making sure it meets the specifications in the chapter.

Figure 6-9

All Type A2 Delta Purifiers manufactured after October 2003 are equipped with an external guillotine-style damper to control the volume of air exhausting from the cabinet.

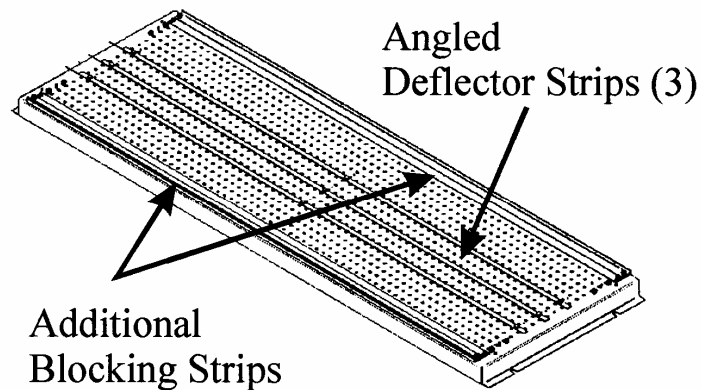

To adjust the damper:

1. Using a 7/16" nut driver or socket, locate the damper adjustment bolt on the front of the damper assembly, as shown in Figure 6-10.
2. Turn the bolt clockwise to open the damper and increase the volume of air being exhausted. Turn the bolt counterclockwise to reduce the exhaust flow.
3. If using a direct read instrument or flow hood to establish the exhaust volume, allow the instrument's readings to stabilize at least 30 seconds before readjusting the damper.

Canopy Airflow Adjustment

Balancing of airflows in the cabinet is accomplished by adjustment of the cabinet's exhaust control system and speed control. The exhaust system should be considered a separate system, distinct from the Purifier.

Changing the damper setting or the speed control will affect the inflow and downflow values. Both must be checked after any adjustment.

Downflow and inflow values and measurement procedures for the Purifier are described fully in Chapter 6: Maintaining Your Purifier.

After adjusting the cabinet inflow and downflow to specifications, the airflow in the exhaust duct can be determined by calculating the Total Exhaust volume and subtracting the cabinet inflow volume from it.

Canopy exhaust volumes are listed in appendix E

Measuring the Total Exhaust Volume

Measure the airflow in the exhaust duct in accordance with American Society of Heating, Refrigerating and Air-Conditioning Engineers (ASHRAE) recommended procedures. It should correspond to the airflow values shown in Appendix E.

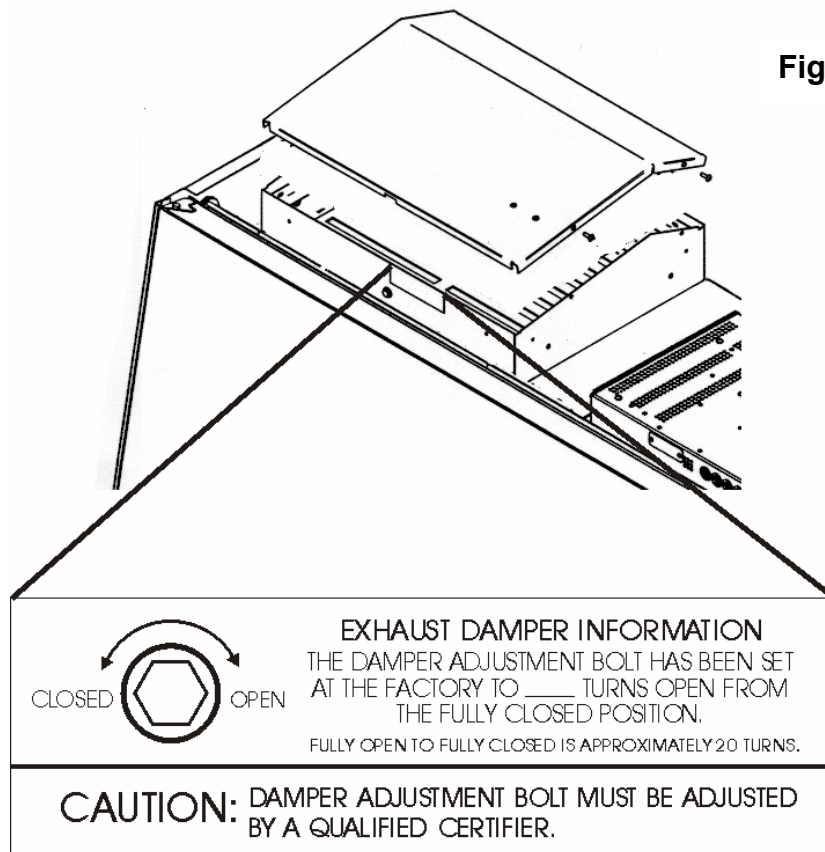

Figure 6-10

Use of the Access Tube For DOP Testing

The Purifier utilizes a unique access tube for sampling the upstream concentration of DOP. If after reading these instructions, you have further questions; please contact Labconco's Product Service Department.

Note: The access tube contains contaminated air under positive pressure. DO NOT access this line until the cabinet has been decontaminated. A qualified certification technician as part of the recertification procedure should only perform DOP scanning of the HEPA filters.

1. Remove the work surface as shown in Figure 6-1.
2. Locate the access tube on left side of the rear plenum wall, behind the towel catch.
3. Pull the tube toward the front of the unit. Remove the access tube's cover.
4. Using an appropriate photometer, connect the unit's upstream line to the access tube.
5. After completing the DOP test of the filters, replace the access tube cover, ensuring that it is sealed properly.
6. Replace the access tube, and the work surface.

HEPA Filter Replacement

The cabinet must be properly decontaminated before servicing the supply HEPA filter. A qualified certification technician should only service the HEPA filters. Following replacement of a HEPA filter, a qualified certification technician MUST recertify the cabinet.

1. Unplug the cabinet.
2. Remove the front dress panel as shown in Figure 6-2.
3. Remove the sash pocket by loosening the two Phillips screws on the left side of the pocket. Support the sash pocket while removing the two screws on the right side of the sash pocket. Swing the sash pocket out and away from the unit as shown in figure 6-11.

Figure 6-11

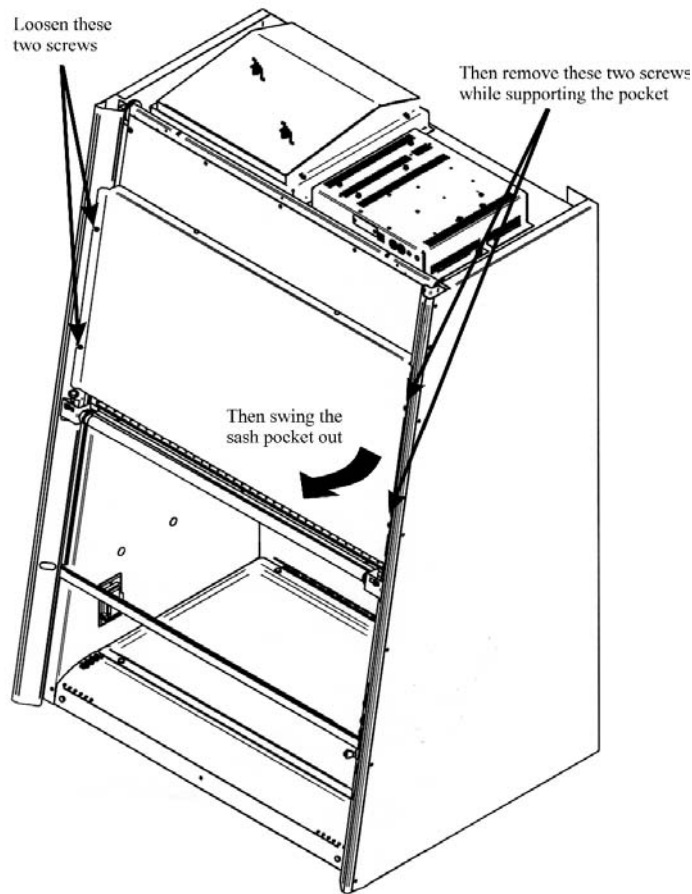

4. Loosen and remove all of the Phillips screws on the blower chamber cover. Gently rock the cover, slide it to the left or right, and swing it out and away from the unit.
5. Using a 1/2-inch wrench, loosen the four locking bolts that contact each corner of the plenum box at least 1/2 inch, as shown in Figure 6-12.
6. Loosen the four exhaust filter sealing bolts located at each corner of the exhaust filter tray, as shown in Figure 6-12 at least 1/2 inch. This releases the exhaust HEPA filter from the cabinet.

Figure 6-12

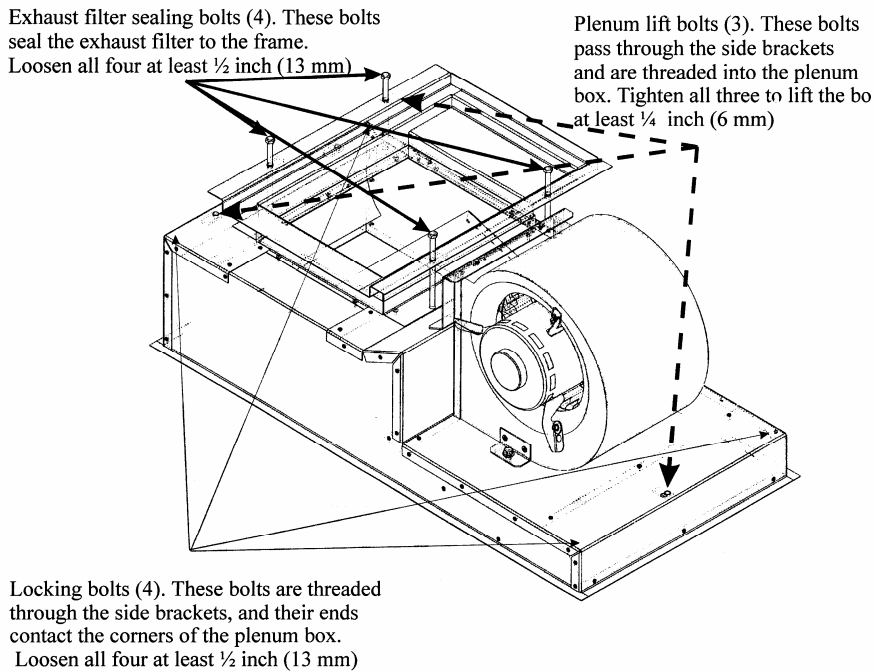

To Remove the Exhaust HEPA Filter:

The exhaust HEPA filter is awkward to handle and heavy. Use appropriate lifting techniques to remove and handle it. Use two people to remove the filter if possible.

1. Slide the exhaust HEPA filter out of the filter pan.

To Remove the Supply HEPA Filter:

The supply HEPA filter is awkward to handle and heavy. Use appropriate lifting techniques to remove and handle it. Use two people to remove the filter if possible.

1. With the exhaust filter removed, use a 1/2-inch socket or wrench to tighten the three plenum lift bolts located as noted in Figure 6-12. This will lift the plenum box off the supply HEPA filter.
2. Slide the supply HEPA filter straight out the unit.
3. With the HEPA filters removed, inspect the filter shelf and the exhaust filter tray for damage.

To Install a Supply HEPA Filter:

1. Install a new supply HEPA filter by pushing it straight into the cabinet, ensuring that it is correctly oriented, and that the filter is centered on the filter shelf.
2. Use a 1/2-inch socket or wrench to sequentially loosen the three plenum lift bolts located as noted in Figure 6-12. When properly positioned, the plenum box will be aligned with the supply HEPA filter frame, and there will be an approximately 1/4 inch gap between the bottom of the plenum lift bolt head and the top of the lift bracket. This will allow the plenum box to properly seat as the filter gasket is compressed.
3. Using a 1/2-inch wrench, tighten the four locking bolts located at each corner of the plenum box, as shown in Figure 6-12 until the supply HEPA filter gasket is compressed to approximately 50% of its thickness.

The locking bolts should only be tightened enough to ensure a proper seal of the supply HEPA filter. At maximum tightness, the supply filter's gasket should be compressed to 50% of its original thickness. NEVER tighten the locking bolts beyond this setting.

To Install an Exhaust HEPA Filter:

1. Slide the new exhaust HEPA filter all the way into the pan.
2. Sequentially tighten the four exhaust filter sealing bolts located at each corner of the exhaust filter tray, as shown in Figure 6-12 until the exhaust filter gasket is compressed approximately 50%.

The exhaust filter sealing bolts should only be tightened enough to ensure a proper seal of the exhaust HEPA filter. At maximum tightness, the exhaust filter's gasket should be compressed to 50% of its original thickness. NEVER tighten the bolts beyond this setting.

3. Install the blower chamber cover, uniformly tightening the screws on the cover until the gasket has formed a proper seal.
4. Install the sash pocket.
5. Install the front dress panel.
6. Plug in the cabinet and have it recertified before use.

Motor/Blower Maintenance and Replacement

The cabinet must be properly decontaminated before servicing the motor/blower.

A qualified certification technician should service the motor/blower.

The cabinet blower motor's bearings are sealed and require no lubrication. DO NOT attempt to lubricate them.

To replace the Motor/Blower:

1. Unplug the cabinet.
2. Remove the front dress panel as shown in Figure 6-2.
3. Remove the sash pocket as shown in Figure 6-11.
4. Loosen and remove all of the Phillips screws on the blower chamber cover. Gently rock the cover, slide it to the left or right, and swing it out and away from the unit.
5. Using a screwdriver, disconnect the motor ground wire from the blower housing.
6. Disconnect the motor leads from the wiring harness by pulling apart each of the 4 connectors.
7. Using a 1/2-inch wrench, remove the two upper and one lower blower mounting bolts, as shown in Figure 6-13.

The motor/blower assembly is heavy. Handle with care.

8. While supporting the blower assembly, pull the assembly straight out the plenum.
9. To replace the motor/blower assembly, reverse the above procedure.
10. Plug in the cabinet and have it recertified before use.

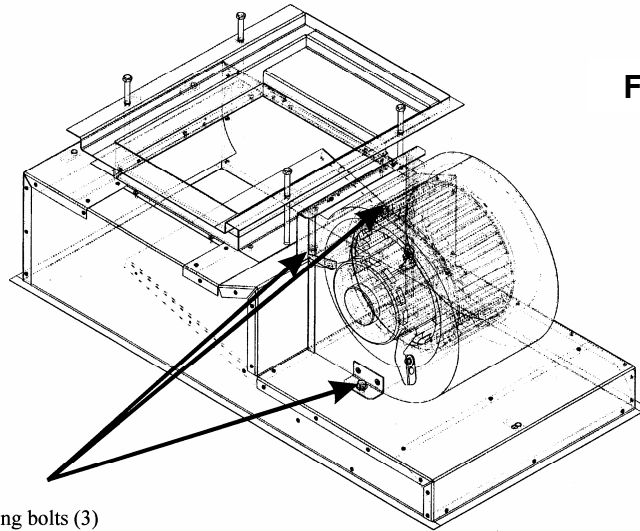

Figure 6-13

Blower mounting bolts (3)

Diffuser Removal

Note: The work area of the cabinet must be thoroughly disinfected before removing the diffuser. Before removing the diffuser, note its orientation. It can only be installed one way. Bending or distorting the diffuser may affect the airflow in the cabinet. Use care when handling it. When properly installed, the rear edge of the diffuser should rest on the diffuser support brackets located on the rear wall of the work area as shown in Figure 6-14.

1. Shut off the Purifier and raise the sash to the full open position. If the diffuser extends to the front of the filter shelf, remove the sash pocket, as described in Figure 6-11.
2. Remove the fasteners located in the front or lower front edge of the supply HEPA filter shelf.
3. Carefully lower the diffuser. Remove it by tilting the front edge down.
4. Install the diffuser and restrictor plate by reversing the above steps.

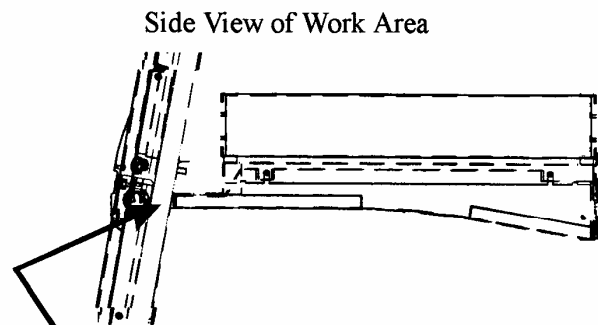

Remove the diffuser mounting screws (3 or 4) then swing the front of the diffuser down, and then pull it straight out.

Figure 6-14

Storage

If the Purifier cabinet is to be left unused for more than one month, the unit should be prepared for storage.

Note: The cabinet should not be stored in areas of excess humidity or temperature extremes. If the cabinet is moved during storage, it must be recertified before use.

1. Close the sash completely and seal the bottom edge and the exhaust outlet with plastic sheeting.
2. Unplug the unit.
3. Ensure that the cabinet will not be moved or disturbed while in storage.

Decontamination

Trained personnel should only perform gaseous decontamination.

To seal the Purifier follow these steps:

1. Remove the front dress panel as shown in Figure 6-2. Remove the sash pocket as shown in Figure 6-11. Place decontamination equipment inside the work area of the Purifier. Remove the sash stops from the lower front edge of the unit. Raise the sash until the diffuser is uncovered.

The outlets on the interior of the Purifier are energized as long as the Purifier is plugged in. Unplug the Purifier before decontamination equipment is plugged into these outlets.

2. Remove the grille by loosening and removing the thumbscrews on the front of the grille and at the front edge of the worksurface. Place the grille within the work area.
3. Use duct tape and 5 to 8 mil plastic sheeting to seal the front opening.
4. Remove the exhaust control system from the top of the cabinet and seal the exhaust filter opening with plastic sheeting and duct tape.
5. Perform the decontamination as described in NSF Standard 49:2002, Annex G.

CHAPTER 7: Modifying Your Cabinet

There are several ways to modify your Purifier for your individual requirements. These include the addition of a UV lamp, service fixtures or an intravenous (IV) bar or a canopy connection kit.

Installing a UV Lamp

All Labconco Purifier Delta Series Safety Cabinets are pre-wired for the installation of a UV lamp.

3, 4 and 5-foot units require the installation of a UV lamp kit, consisting of the UV lamp, its ballast, and fasteners. The kit is part number 37450-00 for 115 Volt models, 37450-01 for 230 Volt units.

A qualified electrician or certifier should install the UV lamp kit.

Completely surface decontaminate all interior work surfaces of the Purifier before beginning the installation of the UV lamp.

To install the UV lamp kit for the 3', 4' and 5' do the following:

1. Unplug the unit.
2. Using a 7/16-inch wrench or socket, remove the two acorn nuts that secure the electronics module to the top of the Purifier as shown in Figure 6-3.
3. Tilt the electronics module back to access the underside of the module.
4. Locate the fluorescent lamp ballast in the module. The UV lamp ballast mounts next to the fluorescent ballast.

6-foot units only require the installation of the UV lamp. The lamp is part number 12713-00.

Completely surface decontaminate all interior work surfaces of the Purifier before beginning the installation of the UV lamp.

To install the UV lamp kit for the 6' do the following:

1. Unplug the unit, and raise the sash to the full open position.
2. Install the UV lamp by pushing it into the left socket, and compress the socket, swinging it into the right lamp socket.
3. Lower the sash to fully closed position, plug in the unit, and turn the system power switch to the "UV" position. The UV lamp will illuminate.

Installing Additional Service Fixtures

Completely surface decontaminate all interior work surfaces of the Purifier before beginning the installation of the service valve.

Additional service fixtures can be installed in any of the four available service fixture holes in both sidewalls. The service fixture kit is Labconco part number 3747500. To install the service fixture:

1. Decide into which of the available locations you want to install the service fixture.
2. Remove the side panel on that side of the unit as shown in Figure 3-2.
3. Remove as much of the silicone sealant as possible from around the outside of the service fixture hole plug.
4. Placing a block of wood or plastic against the outside edge of the plug, and using a small hammer, *gently* tap the plug out of the hole.

Do not use excessive force in attempting to remove the hole plug. Damage to the sidewall of the cabinet could occur.

5. Carefully remove any remaining sealant from both sides of the service fixture hole.
6. Using the Teflon tape supplied, wrap two to three turns of tape on the male pipe thread of the valve, and the tube fitting.

7. Put the threaded end of the fixture through the hole, orienting the valve as shown in Figure 3-6. Using the silicone sealant, apply a bead of silicone on the outside surface of the cabinet side, around the valve body. This will provide a pressure tight seal around the valve body. Place the two washers on the valve thread, and then install the coupler. Holding the valve body in position, use a wrench or pliers to thread the coupling on until the valve is captured on the side panel.
8. Thread the tubing connector onto the coupling until it can no longer be turned by hand. Holding the coupling secure with a wrench or pliers, turn the tube fitting approximately one more revolution, using pliers or a wrench. Orient the tube fitting such that it is easy to access it with the incoming service tube.
9. Connect the service tube to the tube fitting by pressing the tube all the way into the fitting, turning the tubing nut until hand tight, and then approximately one more turn using pliers or a wrench.

Make sure the service tubing does not obstruct the wiring or sash weights or cables.

10. Make sure the service fitting in the Purifier is in the off position before pressurizing the service line. Once pressurized, check the valve body, the coupling, and the tube fitting for leaks. Tighten any leaking joints.
11. Reattach the side panel.
12. The valve is shipped with a white plastic index disc. This disc can be replaced with the orange or yellow disc supplied by unscrewing it and replacing it with the new one.

Installing the IV Bar for the 3' and 4'

Completely surface decontaminate all interior work surfaces of the Purifier before beginning the installation of the IV bar.

1. Shut off the Purifier and raise the sash to the fully open position.
2. Remove the four black protective caps on the sidewalls and discard them.
3. Mount one of the IV brackets on the two studs on either sidewall. Orient the bracket so that the center section of the bracket is offset away from the side of the Purifier sidewall. Secure the bracket using the flat washers, lock washers, and acorn nuts as shown in Figure 7-2.
4. Slide the other bracket onto the IV bar, and install it to the sidewall in the same position as the bracket on the other sidewall, as shown in Figure 7-2.
5. Secure the end brackets by tightening all of the fasteners.

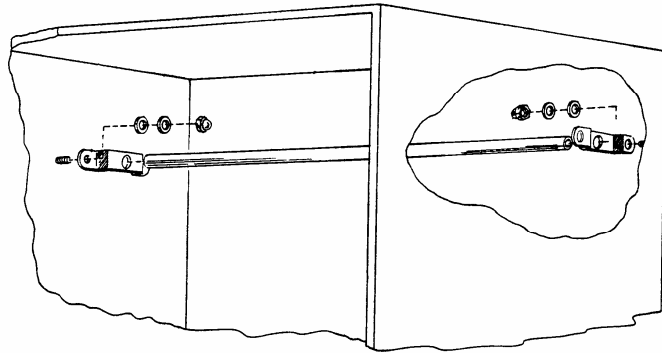
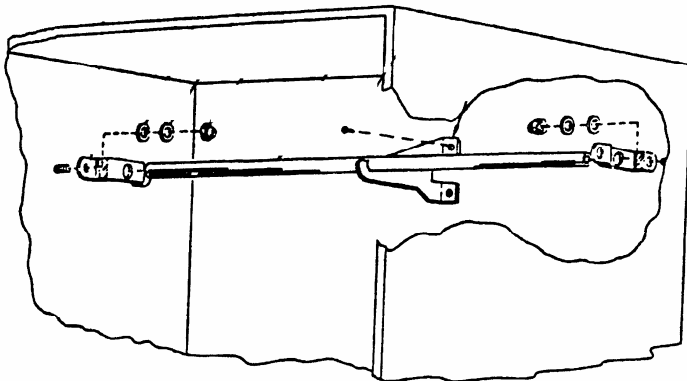

Figure 7-2

Installing the IV Bar for the 5' and 6'

1. Shut off the Purifier and raise the sash to the fully open position.
2. Remove the four black protective caps on the sidewalls and discard them.
3. Mount one of the IV brackets on the two studs on either sidewall. Orient the bracket so that the center section of the bracket is offset away from the side of the Purifier sidewall. Secure the bracket using the flat washers, lock washers, and acorn nuts as shown in Figure 7-2.
4. Insert the center support brace on the IV Bar. Slide the other bracket onto the bar and install it to the sidewall in the same position as the bracket on the other wall, as shown in Figure 7-3.
5. Secure the center support brace and the end brackets by tightening all of the fasteners.

Figure 7-3



Canopy Connection Kits

The canopy kit needed depends on the configuration of the exhaust control system of your Delta. Biosafety Cabinets manufactured on or before September 2003, with a serial number starting at 0309 or lower may be equipped with a variable orifice exhaust control system,

as shown in Figure 7-4. Deltas equipped with this type of exhaust control system must be updated to a newer guillotine-style damper system and canopy. The part numbers for these kits are:

Table 7-1

Damper-Canopy Kit Number	Purifier Width
3808000	3 feet
3802800	4 feet
3802900	6 feet

If your Delta was manufactured during or after September 2003, with a serial number of 0309 or higher, it may be equipped with the guillotine-style damper, as shown in Figure 7-5. They only require the canopy connection itself. The part numbers for these kits are:

Table 7-2

Canopy Kit Number	Purifier Width
3794400	3 Feet
3794500	4 Feet
3794600	5 and 6 Feet

Verify the kit you have ordered is the correct one for your Purifier.

Figure 7-4

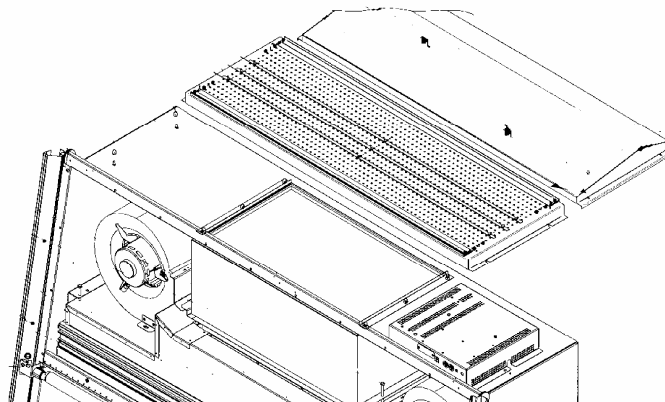
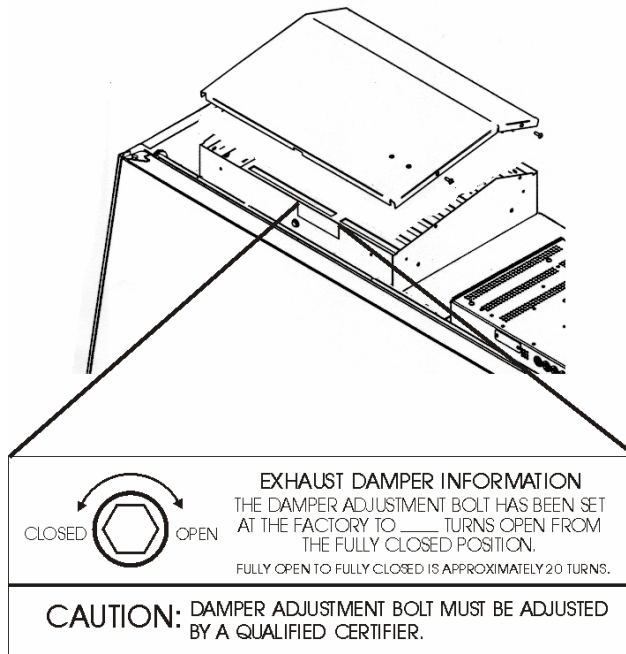

Figure 7-5



Exhaust System Requirements

The Canopy Connection Kit is sized to accept 10-inch ductwork. The exhaust system's blower should be sized to handle the exhaust volume of each cabinet, as shown in Table 3-3, with a static pressure equal to or greater than the system pressure, plus 0.2 inches of water.

The exhaust system should be fitted with a backdraft damper to prevent the reversing of airflow in the system.

Labconco manufactures exhaust blowers with integral backdraft dampers, part number 36680-00 and 36680-01, which is suitable for most single cabinet installations. The remote blower is discussed further in Appendix D.

Table 7-3

Purifier Canopy Airflow Data				
Model Number	Average Inflow Velocity (FPM)	Work Opening Area (sq. ft.)	Exhaust Volume of Cabinet (CFM)	Exhaust Volume of Thimble (CFM)
36204	105	2.53	253-278	303-334
36205	105	2.03	203-223	244-268
36208	105	3.37	337-370	404-444
36209	105	2.69	269-296	323-355
36200	105	4.20	420-462	546-601
36201	105	3.36	336-370	437-481
36212	105	5.03	503-554	654-720
36213	105	4.03	403-443	524-576

Installing the Canopy Kit

A qualified certifier or contractor should install the Canopy Kit and its connection to the exhaust duct.

Installing a canopy connection and exhaust system will impact the performance of the Purifier. **DO NOT** attempt to use the cabinet until it has been properly certified as described in this chapter.

Use caution when removing or installing components on top of the exhaust filter. When exposed, the surface of the HEPA filter is very fragile and can be damaged easily. If you suspect that the exhaust filter has been damaged during the installation of the canopy,

DO NOT use the cabinet; have it certified by a qualified certifier before using it.

On Delta models with the variable orifice system:

1. Remove the orange exhaust cover, the exhaust control cover and the two reinforcing angles as shown in Figure 7-6. Discard these parts.
2. Install the new Damper-Canopy assembly, securing it to the six studs located on the top of the Delta that secured the reinforcing angles. Ensure that the damper adjustment bolt faces the front of the Delta.
3. Connect the exhaust stack to the exhaust system, preferably using a flexible duct connection sized for 10-inch duct.

Figure 7-6



On Delta models already equipped with the guillotine damper:

1. Remove the orange exhaust cover as shown in Figure 7-7. Retain the four screws for later use. Retain the exhaust cover if the Delta will be converted back to re-circulating operation in the future.
2. Install the new Canopy assembly securing it to the damper assembly by using the four screws removed from step #1. Ensure that the damper adjustment label faces the front of the Delta.
3. Connect the exhaust stack to the exhaust system, preferably using a flexible duct connection sized for 10-inch duct.

Figure 7-7

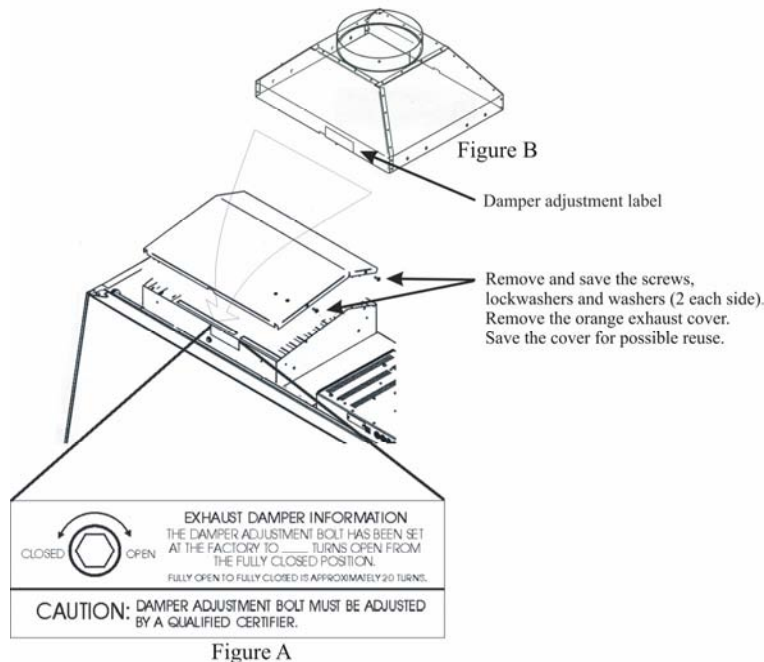

Chapter 8: Troubleshooting

Refer to the following table if your Purifier fails to operate properly. If the suggested corrective actions do not solve your problem, contact Labconco for additional assistance.

PROBLEM	CAUSE	CORRECTIVE ACTION
Cabinet blower and lights won't turn on	Unit not plugged into outlet	Plug the Purifier into appropriate electrical service. Check connection to control box on top of unit.
	Circuit breakers tripped	Reset circuit breakers.
Blower won't turn on but lights work	Sash closed	Raise sash.
	Blower wiring is disconnected	Inspect blower wiring.
	Blower motor is defective	Replace blower motor.
Cabinet blower turns on but lights don't work	Lamp not installed correctly	Inspect lamp installation.
	Lamp is defective	Replace lamp.
	Lamp circuit breaker tripped	Reset the lamp circuit breaker.

PROBLEM	CAUSE	CORRECTIVE ACTION
Cabinet blower turns on but lights don't work (cont.)	Lamp wiring is disconnected	Inspect lamp wiring.
	Defective lamp ballasts	Replace lamp ballasts.
Slight increase in pressure reading	HEPA filter loading	The pressure reading will steadily increase as the unit is used.
	Blockage of the return air slots or grille	Check all return air slots and grilles to ensure that they are not blocked or restricted.
	Blockage of the exhaust outlet	Ensure that the exhaust outlet is not blocked or restricted.
	Blockage or restriction under the work surface	Ensure that the plenum beneath the work surface is unobstructed.
Contamination of work in the cabinet	Improper technique or procedure for the biohazard cabinet	See "Use of the Cabinet" section in the manual.
	Restriction of the return air slots or grille – blockage of the exhaust outlet	Ensure that all return air slots, grilles and the exhaust outlet are unobstructed.
	External factors are disrupting the cabinet airflow patterns or acting as a source of contamination	See "Installation" section of this manual.
	Cabinet is out of adjustment/HEPA filter(s) are defective	Have cabinet recertified.

Appendix A: Components

Illustration A-1 indicates the location of the following service parts:

Purifier Replacement Parts

Item	Quantity	Part No.	Description
1	1	3734000	Side Panel, R.H.
2	1	3734001	Side Panel, L.H.
3	1	3739500	Exhaust HEPA Filter 3-ft
3A	1	3739501	Exhaust HEPA Filter 4-ft
3B	1	3739503	Exhaust HEPA Filter 5-ft
3C	1	3739502	Exhaust HEPA Filter 6-ft
4	1	3731100	Motor/Blower Assy, 115 VAC 3-ft, 6-ft Right
4A	1	3731101	Motor/Blower Assy, 115 VAC 4 & 5-ft
4B	1	3731102	Motor/Blower Assy, 115 VAC 6-ft Left
4C	1	3757100	Motor/Blower Assy, 100 VAC 3-ft, 6-ft Right
4D	1	3757101	Motor/Blower Assy, 100 VAC 4 and 5-ft
4E	1	3757102	Motor/Blower Assy, 100 VAC 6-ft Left
4F	1	3751900	Motor/Blower Assy, 230 VAC 3-ft, 6-ft Right
4G	1	3751901	Motor/Blower Assy, 230 VAC 4 and 5-ft
4H	1	3751902	Motor/Blower Assy, 230 VAC 6-ft Left
5	1	1211200	Motor, 115 VAC 3- and 4-ft
5A	1	1210503	Motor, 100 VAC 3- and 6-ft
5B	1	1210501	Motor, 100 VAC 4 and 5-ft
5C	1	1210502	Motor, 230 VAC 3-ft
6	1	3739400	Supply HEPA Filter 3-ft
6A	1	3739401	Supply HEPA Filter 4-ft
6B	1	3739403	Supply HEPA Filter 5-ft
6C	1	3739402	Supply HEPA Filter 6-ft
7	1	9721901	Lamp, Fluorescent, 3-ft
7A	1	9721900	Lamp, Fluorescent, 4-ft
7B	1	9721903	Lamp, Fluorescent, 5-ft
7C	1	1278400	Lamp, Fluorescent, 6-ft
8	1	1271300	Lamp, UV, 3, 4 and 5-ft (not shown)
8A	1	1231900	Lamp, UV, 6-ft (not shown)
9	2	1287900	Receptacle Cover

A-1

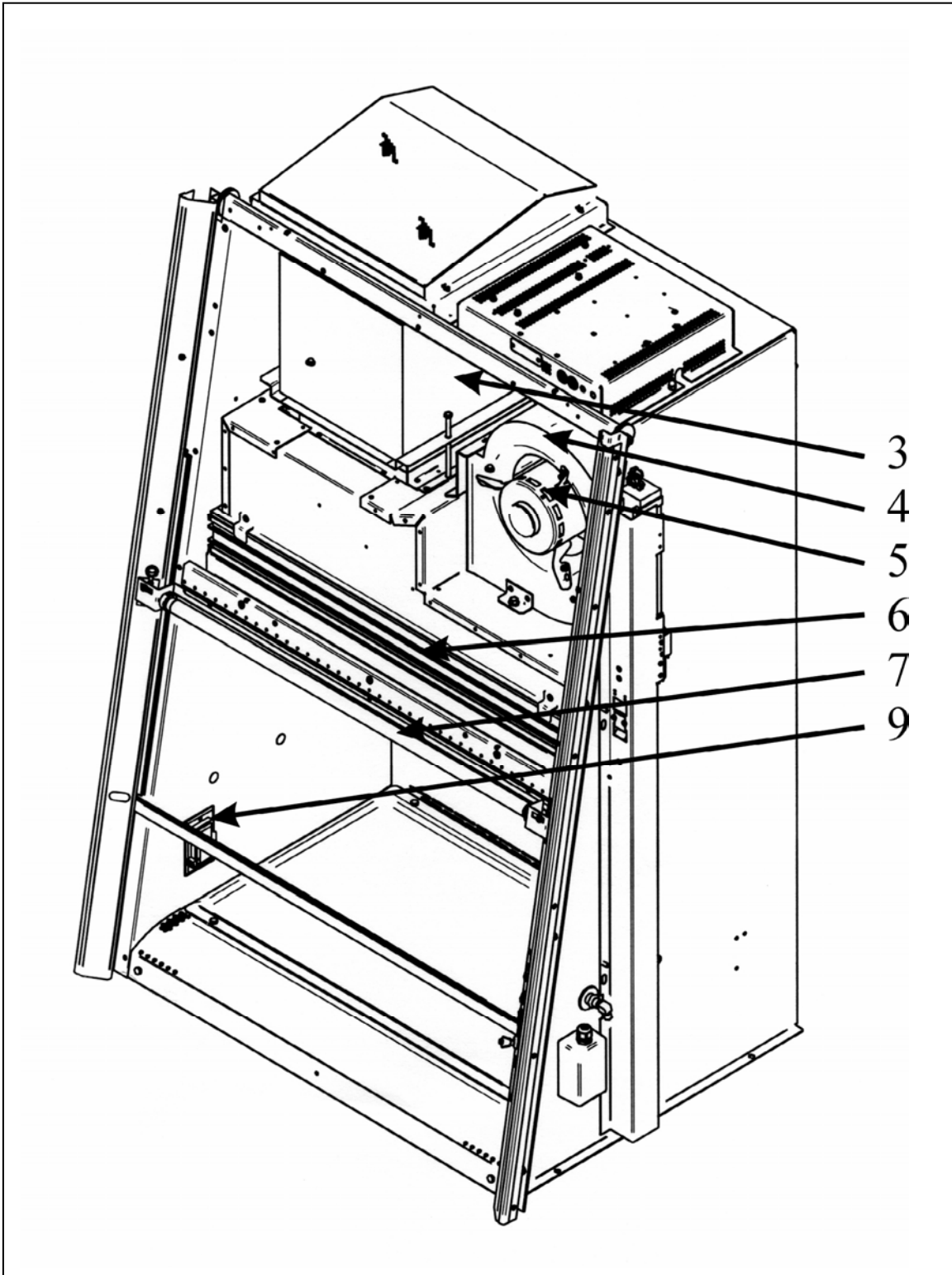

Appendix B: Dimensions

B-1

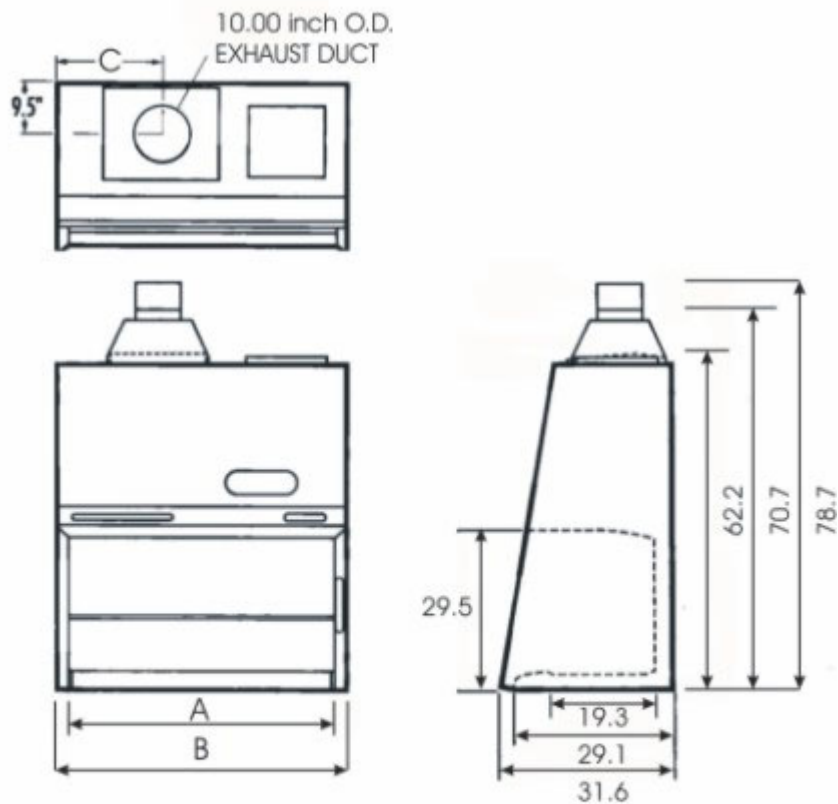

Purifier Model	A	B	C
3-foot	36.5	42	13.1
4-foot	48.5	54	19.1
5-foot	60.5	66	22.0
6-foot	72.5	78	39.0

All dimensions in inches.

Appendix C: Specifications

Electrical Data

Cabinet Model	Electrical Requirements
3620400 to -09 & 3620500 to -09	115 VAC – 60 Hz, 1 Phase – 12 Amps
3620800 to -09 & 3620900 to -09	115 VAC – 60 Hz, 1 Phase – 12 Amps
3620000 to -09 & 36210100 to -09	115 VAC – 60 Hz, 1 Phase – 12 Amps
3621200 to -09 & 3621300 to -09	115 VAC – 60 Hz, 1 Phase – 16 Amps

Cabinet Model	Electrical Requirements
3620510 to -19	100 VAC – 50/60 Hz, 1 Phase – 12 Amps
3620910 to -19	100 VAC – 50/60 Hz, 1 Phase – 12 Amps
3620110 to -19	100 VAC – 50/60 Hz, 1 Phase – 12 Amps
3621310 to -19	100 VAC – 50/60 Hz, 1 Phase – 16 Amps

Cabinet Model	Electrical Requirements
3620520 to -29	230 VAC – 50/60 Hz, 1 Phase – 7 Amps
3620920 to -29	230 VAC – 50/60 Hz, 1 Phase – 7 Amps
3620120 to -29	230 VAC – 50/60 Hz, 1 Phase – 7 Amps
3621320 to -29	230 VAC – 50/60 Hz, 1 Phase – 8 Amps

Motor Specifications

Cabinet Model	Electrical Requirements
All 115 Vac Models	115 VAC – 60 Hz, 3.8 Full Load Amps 1/3 H.P. 1625 RPM Automatic Thermal Protection

Cabinet Model	Electrical Requirements
3620510 to -19 3621310 to -19	115 VAC – 50/60 Hz, 3.9 Full Load Amps 1/3 H.P. 1625 RPM Automatic Thermal Protection

Cabinet Model	Electrical Requirements
3620910 to -19 3620110 to -19	115 VAC – 50/60 Hz, 6 Full Load Amps 1/2 H.P. 1625 RPM Automatic Thermal Protection

Cabinet Model	Electrical Requirements
3620520 to -29 3621320 to -29	230 VAC – 50/60 Hz, 1.9 Full Load Amps 1/3 H.P. 1625 RPM Automatic Thermal Protection

Cabinet Model	Electrical Requirements
3620920 to -29 3620120 to -29	230 VAC – 50/60 Hz, 2.8 Full Load Amps 1/2 H.P. 1625 RPM Automatic Thermal Protection

Environmental Conditions

- Indoor use only.
- Maximum altitude: 6562 feet (2000 meters).
- Ambient temperature range: 41° to 104°F (5° to 40°C).
- Maximum relative humidity: 80% for temperatures up to 88°F (31°C), decreasing linearly to 50% relative humidity at 104°F (40°C).
- Main supply voltage fluctuations not to exceed $\pm 10\%$ of the nominal voltage.
- Transient overvoltages according to Installation Categories II (Overvoltage Categories per IEC 1010). Temporary voltage spikes on the AC input line that may be as high as 1500V for 115V models and 2500V for 230V models are allowed.
- Used in an environment of Pollution degrees 2 (i.e., where normally only non-conductive atmospheres are present). Occasionally, however, a temporary conductivity caused by condensation must be expected, in accordance with IEC 664.

Appendix D: Accessories

Safety Orange Air Foil

Bold orange color cautions the operator to avoid placing materials in this area where airflow is critical. The airfoil is epoxy-coated stainless steel and may be factory installed or retrofitted on site. Contact Labconco at 800-821-5525, 816-333-8811 or labconco@labconco.com for ordering information.

Telescoping Base Stands

These stands are available with either fixed feet or caster wheels. The user sets the height of these stands before installation of the Delta. The height can be set at 27.5 to 33.5 inches in 1-inch intervals, providing a work surface height of 30.0 to 36.0 inches. The Base Stands for each Delta model are listed below.

Width	Delta Series #	Base Stand w/Feet Model #	Base Stand w/wheels Model #
3'	36204-xx 36205-xx	3730300	3730310
4'	36208-xx, 36209-xx	3730400	3730410
5'	36200-xx 36201-xx	3830500	3830510
6'	36212-xx 36213-xx	3730600	3730610

Manual or Electric Hydraulic Lift Base Stands

These base stands offer infinitely adjustable height between 25.5 and 33.5 inches, giving a work surface height of 28.0 to 36.0 inches. The height is adjusted either by a manual (hand crank) or electric pump that drives hydraulic rams in the legs of the stands. All of the hydraulic stands are equipped with fixed feet, but can be converted to caster wheels with the addition of Caster Wheel Kit #3784000. The Base Stands for each Delta model is listed below.

Width	Delta Series #	Manual Lift Stand #	Electric (115V) Lift Stand #	Electric (230V) Lift Stand #
3'	36204-xx 36205-xx	3780200	3780100	3780103
4'	36208-xx, 36209-xx	3780201	3780101	3780104
5'	36200-xx 36201-xx	3780203	3780106	3780107
6'	36212-xx, 36213-xx	3780202	3780102	3780105

Service Valve Kit (# 3747500)

Includes serrated hose tip valve with quarter turn handle, hardware and instructions for plumbing to services mounts on left or right side interior. All cabinets are factory prepared to accept up to 4 fixtures. Shipping weight 4 lbs. (2 kg).

Ultraviolet Lamp Kits

Includes 254 nm UV lamp. Kit # 3745000 also includes 115-volt ballast.

Catalog #	For use with	Shipping Weight
3745000	3, 4 & 5-foot Purifier Delta Series	5 lbs. (2.3 kg)
3745001	6-foot Purifier Delta Series	3 lbs. (1.4 kg)

IV Bar Kits

Bar supports intravenous solution bottles and bags. Kits include IV bar, mounting hardware, and four hangers.

Catalog #	For use with	Shipping Weight
3745500	3-foot Purifier Delta Series	3 lbs. (1.4 kg)
3745501	4-foot Purifier Delta Series	4 lbs. (1.8 kg)
3745502	6-foot Purifier Delta Series	6 lbs. (2.7 kg)
3745503	5-foot Purifier Delta Series	5 lbs (2.28 kg)

Damper – Canopy Kit

For thimble ducting Purifier Delta Series equipped with a variable orifice control system.

Catalog #	For use with	Duct Dia.	Shipping Weight
3808000	3-foot Delta Purifier	10"	25 lbs. (11.4 kg)
3802800	4-foot Delta Purifier	10"	25 lbs. (11.4 kg)
3802900	6-foot Delta Purifier	10"	25 lbs. (11.4 kg)

Canopy Kit

For thimble ducting the Purifier Delta Series Cabinets equipped with a guillotine damper to the outside.

Catalog #	For use with	Duct Dia.	Shipping Weight
3794400	3-foot Purifier Delta	10"	15 lbs. (7 kg)
3794500	4-foot Purifier Delta	10"	15 lbs. (7 kg)
3794600	5 & 6-foot Purifier Delta	10"	15 lbs. (7 kg)

Remote Blower (# 3668000)

The 1/4 HP motor delivers between 555 CFM @ 0.25" static pressure, and 450 CFM @ 0.5". Belt drive with adjustable sheave. Phenolic coated impeller. Epoxy-coated steel base and weathercover. Integral backdraft damper. Inlet accepts 10" diameter duct. Outlet accepts 8" diameter duct. Maximum duct run of 100 equivalent feet is recommended. Shipping weight 93 lbs. (42 kg).

Remote Blower (# 3668001)

The 1/2 HP motor delivers between 760 CFM @ 25" static pressure and 700 CFM @ 0.5". Drive belt with adjustable sheave. Phenolic coated impeller. Epoxy-coated steel base and weather cover. Integral backdraft damper. Inlet accepts 10" diameter duct. Outlet accepts 8" diameter duct. Maximum duct run of 100 equivalent feet is recommended. Shipping Weight 99 lbs. (45 kg).

Ergonomic Chair with Armrests (# 3744000)

Designed to Biosafety Guidelines. Lab chair has 6-way articulating seat and back control for personalized adjustment. Pneumatic mechanism adjusts seat height from 18 1/4" to 25 3/4". Five-leg black reinforced composite base rests on 2" ball bearing casters. Aluminum support ring. Removable arm rests. Black vinyl upholstery. Shipping weight 35 lbs. (15.9 kg).

Adjustable Footrest (# 3746000)

Elevates feet and permits angle repositioning while in use. 18 1/2"w x 11 1/2"d x 8"h. Shipping weight 6 lbs. (2.7 kg).

Appendix E: Quick Chart

Model	3620400	3620500	3620800	3620900	3620000	3620100	3621200	3621300
Type	A2	A2	A2	A2	A2	A2	A2	A2
Sash Height (inches)	10	8	10	8	10	8	10	8
NSF Listed Downflow (FPM)	50-60	55-65	50-60	55-65	50-60	50-60	55-65	55-65
Sash Open Area (ft ²)	2.53	2.03	3.37	2.69	4.20	3.36	5.03	4.03
*Direct Read NSF Listed Inflow (FPM)	100-110	100-110	100-110	100-110	100-110	100-110	100-110	100-110
*Direct Read Exhaust Volume (CFM)	253-278	203-223	337-370	269-296	420-462	336-370	503-554	403-443
Type B3 Exhaust Volumes (CFM)	253-278	203-223	337-370	269-296	N/A	N/A	503-554	403-443
Type B3 Alarm Setting Volume (CFM)	228 ±5	183 ±5	303 ±5	242 ±5	N/A	N/A	453 ±5	363 ±5
***Canopy Exhaust Volume (CFM)	303-334	244-268	404-444	323-355	420-462	336-370	654-720	524-576
Approximate Settings for new Filters								
Motor Voltage	88-90	85-87	100-102	96-99	110	110	87-90	85-88
Mag Gauge Reading	0.8-1.1	0.8-1.1	0.8-1.1	0.8-1.1	0.8-1.1	0.8-1.1	0.8-1.1	0.8-1.1
Total Air Volume Displacement (CFM)	596	543	794	723	991	903	1189	1083
Number of Laskin Nozzles Needed	1	1	2	2	2	2	2	2
Supply HEPA Filter Dims. (in.)	36x18x3	36x18x3	48x18x3	48x18x3	60x18x3	60x18x3	72x18x3	72x18x3
Exhaust HEPA Filter Dims. (in.)	12x18x12	12x18x12	24x18x12	24x18x12	30x18x12	30x18x12	30x18x12	30x18x12
Motor HP	1/3	1/3	1/3	1/3	1/3	1/3	2 ea. 1/3	2 ea. 1/3
Speed Winding Used	High	High	High	High	High	High	High	High
Capacitor (uF, Volts)	15	15	15	15	15	15	2 ea. 15	2 ea. 15
Fluorescent Light(s)	F25T8/TL741	F25T8/TL741	F32T8/TL741	F32T8/TL741	F40T8/SP41	F40T8/SP41	F72T12/CW	F72T12/CW
UV Light(s)	G30T8	G30T8	G30T8	G30T8	G30T8	G30T8	G64T5L/CB	G64T5L/CB
Secondary Inflow Method Data								
****Sash Height (in.)	6.06	6.06	5.09	5.09	4.50	4.50	4.11	1.99
Distance Between Points	4.07	4.07	4.05	4.05	4.04	4.04	4.03	4.03
Number of Test Points	8	8	11	11	14	14	17	17
Purifier Correction Factor	1.08	1.06	1.13	1.12	1.25	1.25	1.30	1.24

*The Direct Read instrument is sealed to the face or the exhaust opening.
The following calculation is used: Air Volume (CFM) / Sash opening area (Ft²) = Average Face Velocity (FPM).

***This canopy has full width 1-inch slots at the front and back of the canopy.

**** This is the distance from the bottom edge of the sash to the bottom edge of the front grille.

For further details on the secondary inflow method, consult the inflow velocity calculation – Secondary Method section of *Chapter 6: Maintaining Your Cabinet*.

Use the downflow velocity test grid as described on the cabinet data plate when checking the downflow air velocity.

DECLARATION OF CONFORMITY

Application Council Directive(s): 73/23/EEC, 89/336/EEC

Standard(s) to which conformity is declared: EN61010, EN55014, EN55104

Manufacturer's Name: Labconco Corporation

Manufacturer's Address: 8811 Prospect Avenue
Kansas City, MO 64132 USA

Importer's Name: See Shipping/Customs Documents*

Importer's Address: See Shipping/Customs Documents for your equipment

Type of Equipment: Laboratory Equipment

Model No.: Purifier Delta Series Biological Safety Cabinets

36205-24 3 Ft. Wide

36209-24 4 Ft. Wide

36201-24 5 Ft. Wide

36213-24 6 Ft. Wide

Serial No.: Various – See Individual Declaration

Year of Manufacture: 2000 and Subsequent

I, the undersigned, hereby declare that the equipment specified above conforms to the above Directive(s) and Standard(s).

See individual Declaration of Conformity which
will be signed by the importer for your country.

Place:

(Signature)

Date:

(Full Name)

(Position)

*An individual version of this declaration is included with your shipping/customs documentation.

Labconco P/N 36960-20 REV B, B296